

# BE-GE

# BE-GE 8100.0



The seats illustrated are fitted with extra items.



BE-GE 8100.0 is available with both low and high backrest, the high version is ideal for use in combination with a headrest for even more increased comfort during long work shifts and is equipped with adjustable lumbar support as standard.

BE-GE 8100.0 is an air suspended seat especially designed for reach trucks or similar vehicles with limited cab space, which is built to be driven on smooth floors. By placing the suspension unit behind the seat's backrest, the built-in height becomes very low but without decreasing the seats comfort. The seat has simple and ergonomically placed controls for weight adjustment, back adjustment and length adjustment.

Standards:

IT 1  
EN 13490  
FMVSS 302, ISO 3795

# BE-GE 8100.0

**BE-GE 8100.0** is an air suspended seat with the suspension unit placed behind the backrest and with 50 mm suspension. Seat cushion angle is adjustable in four steps. The seat is equipped with integrated compressor and available in 12 V, 24 V and 48 V.

8100.0 high back rest

8102.0 low back rest

Weight adjustment is made via the easy operated handle on the left side of the seat and can be adjusted between 35-150 kg.

## Options:

The seats can be equipped with 24/48V electrical heating, 2-point safety belt and armrests.

The low back can be equipped with manual operated air controlled lumbar support which is standard in the high back version, which also has a headrest as an option.

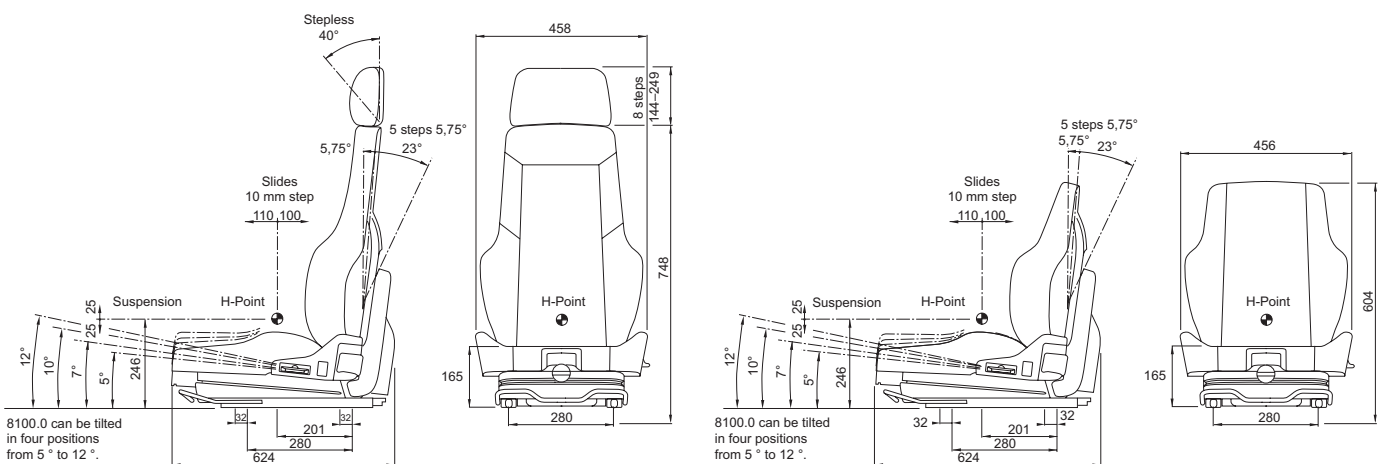
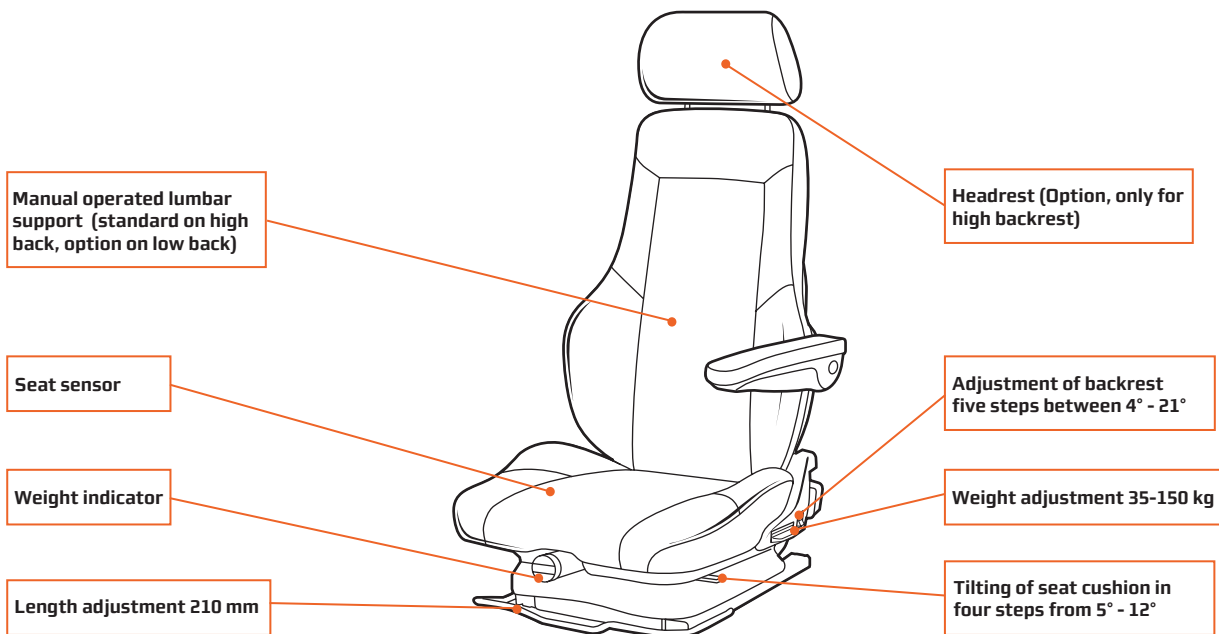

**Be-Ge Seating AB**  
Box 912, SE 572 29 Oskarshamn  
Sweden

PH: +46 491-76 18 00  
FAX: +46 491-819 00

WEB: [seating.be-ge.com](http://seating.be-ge.com)  
E-MAIL: [info.se.seating@be-ge.com](mailto:info.se.seating@be-ge.com)