

BE-GE

BE-GE 3700.39



The seat pictured contains optional features.



The **BE-GE 3700.39** series is an air suspended seat with a separate suspension system. The seat's upper part 3700 has an extra low built profile as along with the suspension package 3909 are very suitable for construction machines and similar vehicles where armrests and vehicle controls are fixed between the seat's upper- and suspension unit.

The excellent comfort of the seat combined with its great flexibility and extra robust suspension system, improves the driver conditions so that they, in the most challenging environments, can work comfortable for long periods.

A large range of options and accessories mean that the seat can be adapted to different requirements.

Standards:

ISO 6683, SAE J386 (2 -point belt)
SAE J2292 (3- and 4-point belt)
FMVSS 302, ISO 3795

BE-GE 3700.39

The **Be-Ge 3700.39** series has as standard a Push-Pull air system, mechanical tilt adjustment, a 640 mm backrest, air-controlled lumbar support, length adjustment of the seat cushion and 200 mm slide rails both between the units and underneath the seat.

Options:

The seat can be fitted with armrests, 4-way headrest (640 mm back), HBC back, electric heating, Airvent, foam with extra side support, 3-point belt with height adjustment as an additional option, 2- or 4-point belt, reinforced slide rails, micro-switch, vibration indicator, built-in compressor, leather cover, air-controlled slide rails, side support and shoulder support.

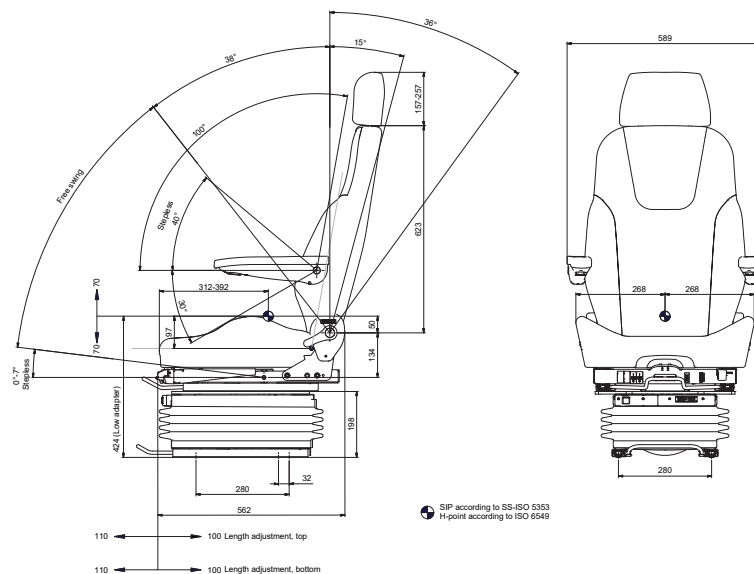
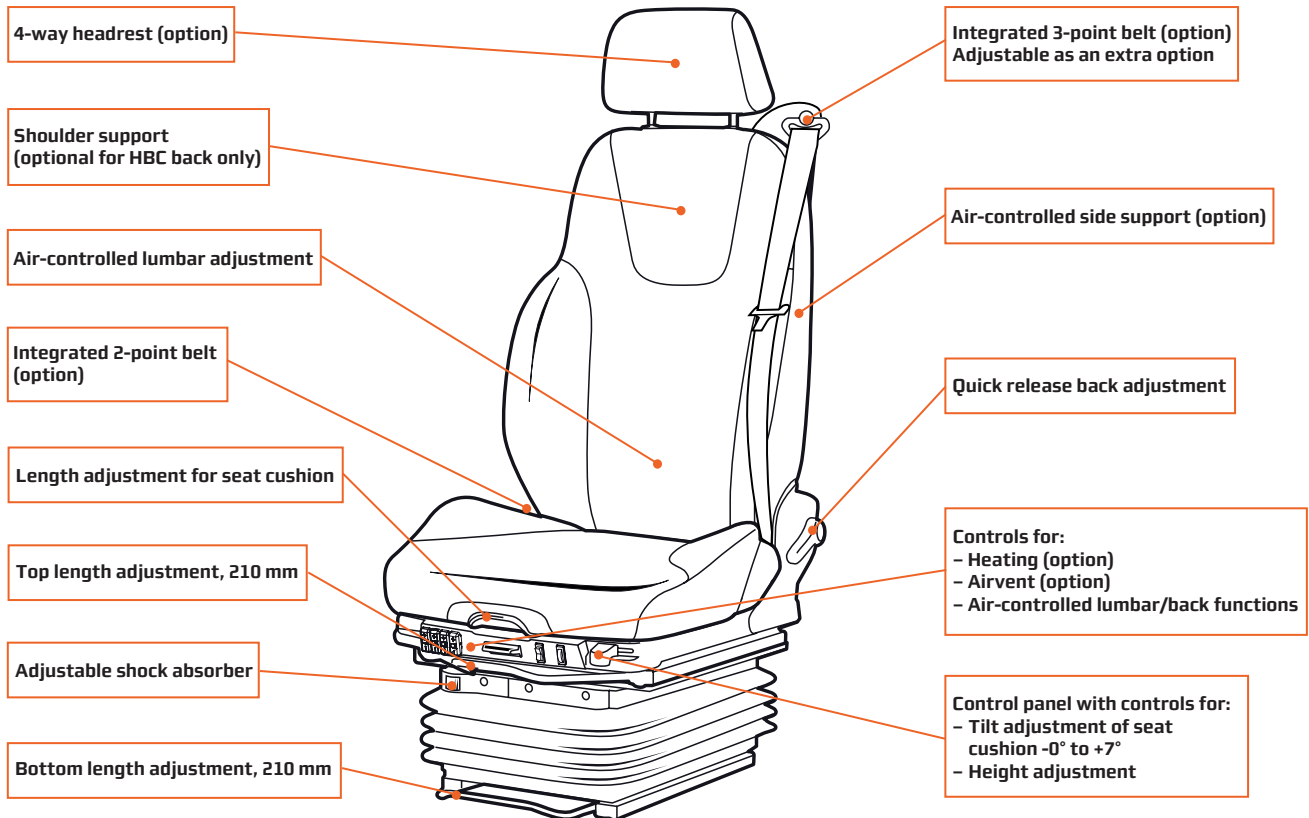

Be-Ge Seating AB
Box 912, SE 572 29 Oskarshamn
Sweden

PH: +46 491-76 18 00
FAX: +46 491-819 00

WEB: seating.be-ge.com
E-MAIL: info.se.seating@be-ge.com