

BE-GE

BE-GE 94-series



The seat on the pictures is extra-equipped.



Comfort line

The seats can be equipped with armrests, headrests, Be-Ge's well-known "Airvent", electric heating, various types of rotary devices, etc. These accessories and options allow the seat to be adapted to the needs.

BE-GE 94-series mean a great deal: not least comfort and quality, both physical and technical.

BE-GE 94-series Softstatic is an almost static seat with limited suspension.

The low mounting height and height adjustment of 180 mm make it very suitable for distribution cars, smaller buses, cranes, boats, etc.

Standards:

SAE J2292 (3-/4-point belt)
ISO 6683, SAE J386 (2-point belt)
R14.07, N2/N3, M2, M3 (3-point belt)
FMVSS 302, ISO 3795, 76/115/EEC

BE-GE 94-series

BE-GE 94-series seat is equipped with limited suspension, lumbar support, protection bellows and sliding rails. The different backrests are standard 640mm, medium 550 mm and low 400 mm. All models can be fitted with lapbelt. The backrest version 640 mm can be equipped with 3-point or 4-point belt and an extra high and stable seat-and backrest foam, XSS or Comfort Line.

Options:

The seat can be equipped with electric heating in the seat and back, Airvent, headrest, armrest, alarm switch, longitudinal damper and various types of bases.

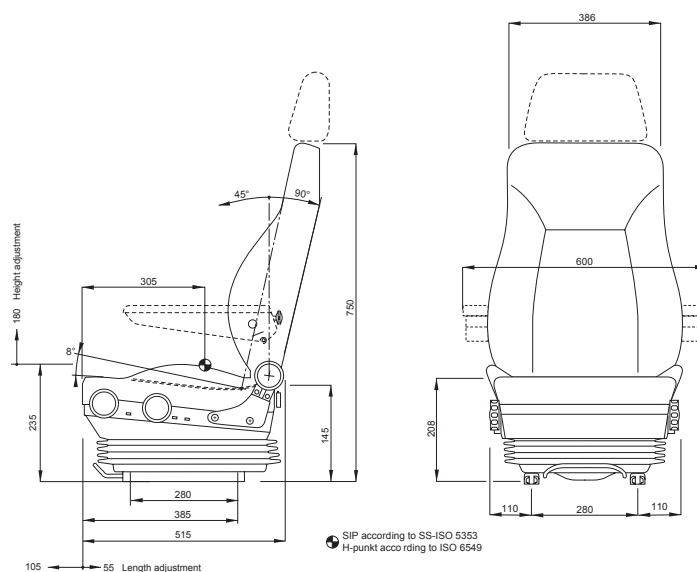
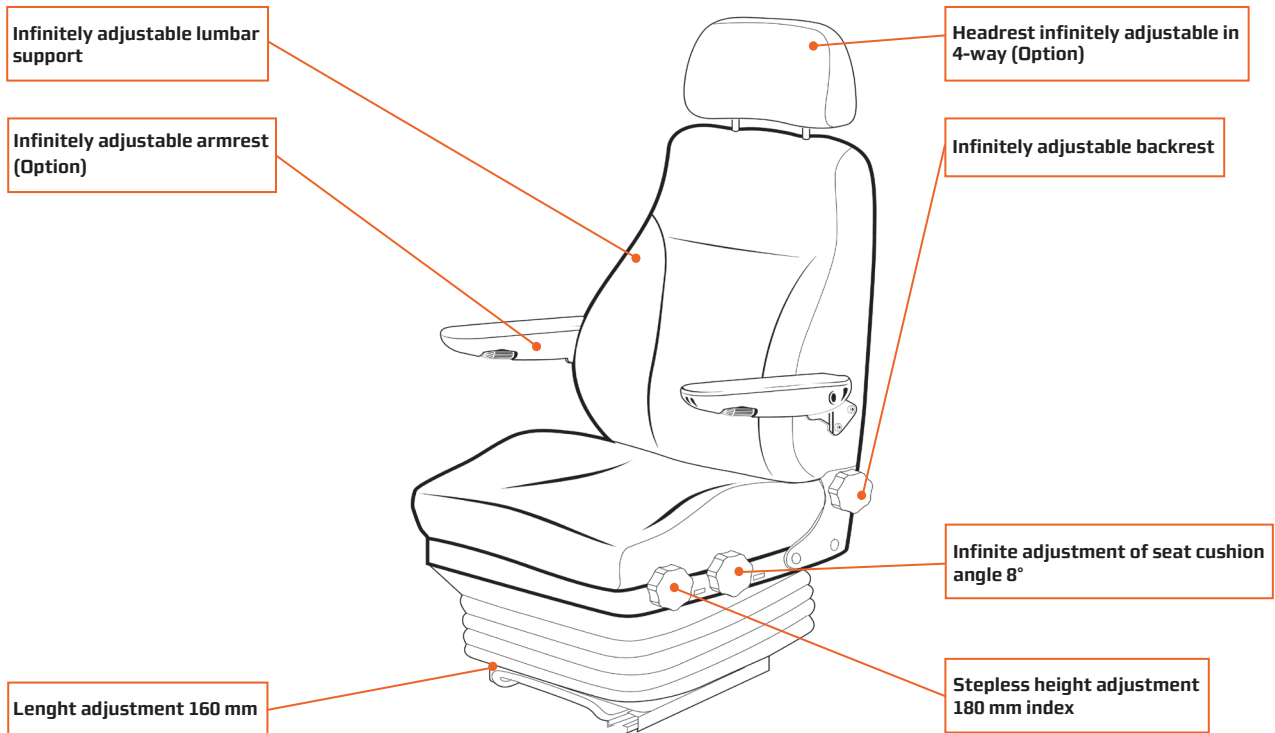

Be-Ge Seating AB
 Box 912, SE 572 29 Oskarshamn
 Sweden

PH: +46 491-76 18 00
 FAX: +46 491-819 00

WEB: seating.be-ge.com
 E-MAIL: info.se.seating@be-ge.com