

BE - GE

Parts Replacements List

7110C4

Doc. R1-7110C4

Date 121018

Rev. 0

Valid from 000801 to

Rev.Date





Parts Replacements List

621686
SEAT BASE 7130

Valid from 020214 to

Doc. R1-621686

Date 120608

Rev. 0

Rev.Date

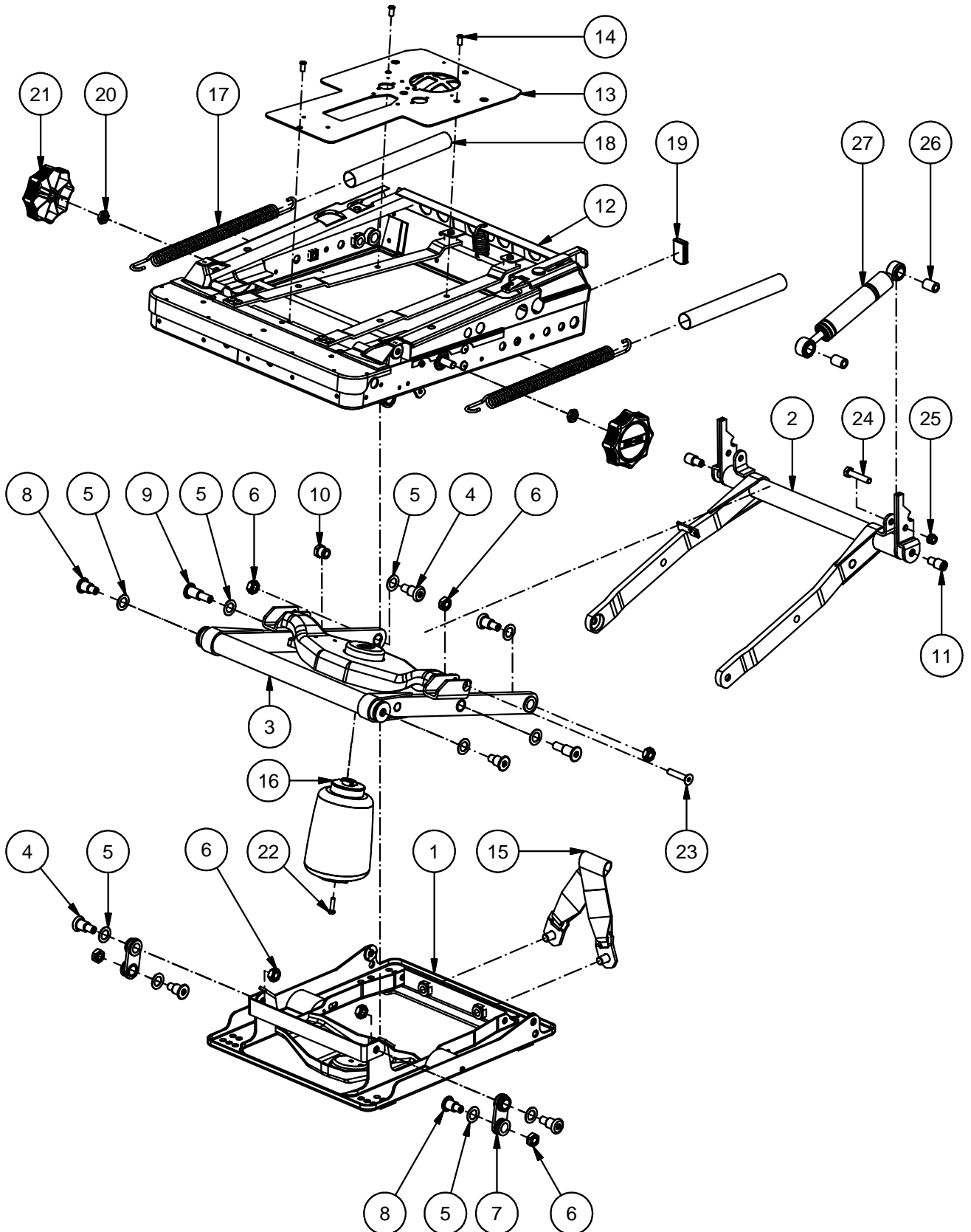



Parts Replacements List

621686
SEAT BASE 7130

Doc. R1-621686

Date 120608

Rev. 0

Valid from 020214 to

Rev.Date

Fig.	Part. No.	Quantity	Description		
1	621631	1	BOTTOM FRAME		
2	621549	1	INNER SCISSOR CPL		
3	621551	1	OUTER SCISSOR CPL		
4	620874	4	BEARING BOLT		
5	500392	10	PLASTIC WASHER		
6	500413	9	NUT LOCK	M10	ZN K8
7	500115	2	SLEWING BRACKET		LOWER
8	500393	4	BEARING BOLT		
9	500330	2	BEARING BOLT		
10	621556	1	BEARING NUT		
11	500396	2	BEARING BOLT		
12	620059P	1	SEATFRAME 9110		
13	620224	1	SEAT PLATE		
14	500223	3	RIVET AL/ST	6.0x12	AP/D BS
15	620022	1	TETHER STRAP		
16	621467	1	AIR SPRING	SZ 38-9 LS	
17	500215	2	BALANCE SPRING		
18	620852	2	INSULATING TUBE		
19	500304	1	PLASTIC KNOB		
20	210403	2	NUT ML6M	M10	DIN439/2 ZN K5
21	621408	2	HAND WHEEL M10		
22	650097	1	SCREW WN156-2	M5x20	ZN
23	650054	1	SCREW MF6S	M8x40	DIN7991 ZN 8.8
24	650015	1	SCREW M6S	M8x40	DIN931 ZN 8.8
25	210401	2	LOCKING NUT	M8	DIN6925 ZN K8
26	620085	2	BUSHING		
27	500122	1	SHOCK ABSORBER		



Parts Replacements List

620061
BACKREST 640 3PB LEFT
9000

Valid from 891214 to

Doc. R1-620061

Date 100705

Rev. 0

Rev.Date

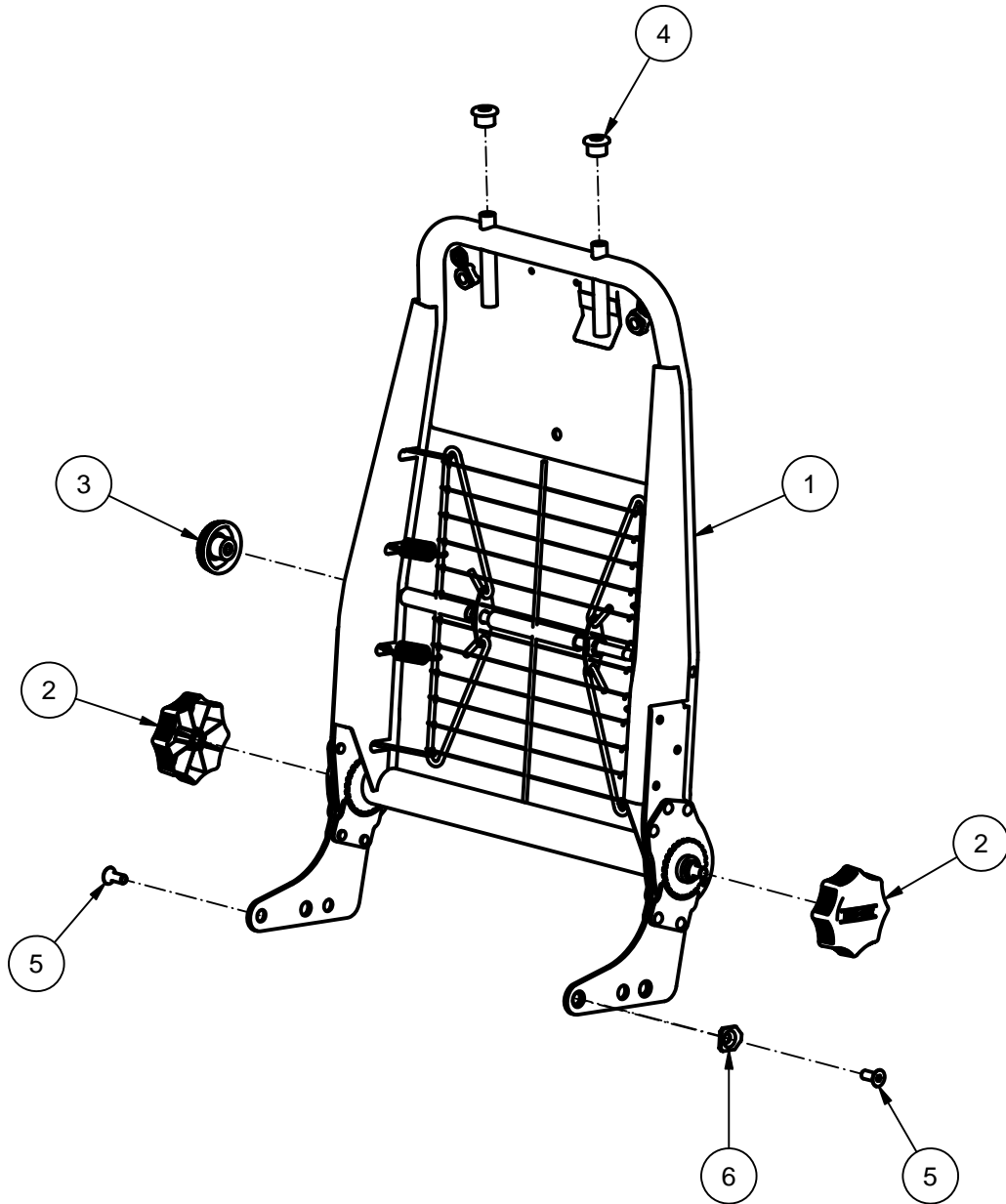

Fig.	Part. No.	Quantity	Description		
1	628092	1	BACK FRAME 640 9000		
2	621408	2	HAND WHEEL M10		
3	500279	1	HANDWHEEL M8		
4	500385	2	HEADREST GROMMET		
5	310930	2	SCREW MF6S	M8x20	DIN7991 ZN-BL 10.9
6	620143	1	EXCENTER WASHER		



Parts Replacements List

621248
BACKFRAME 640V BM 4-WAY LS
7110

Valid from 970401 to

Doc. R1-621248

Date 120608

Rev. 0

Rev.Date

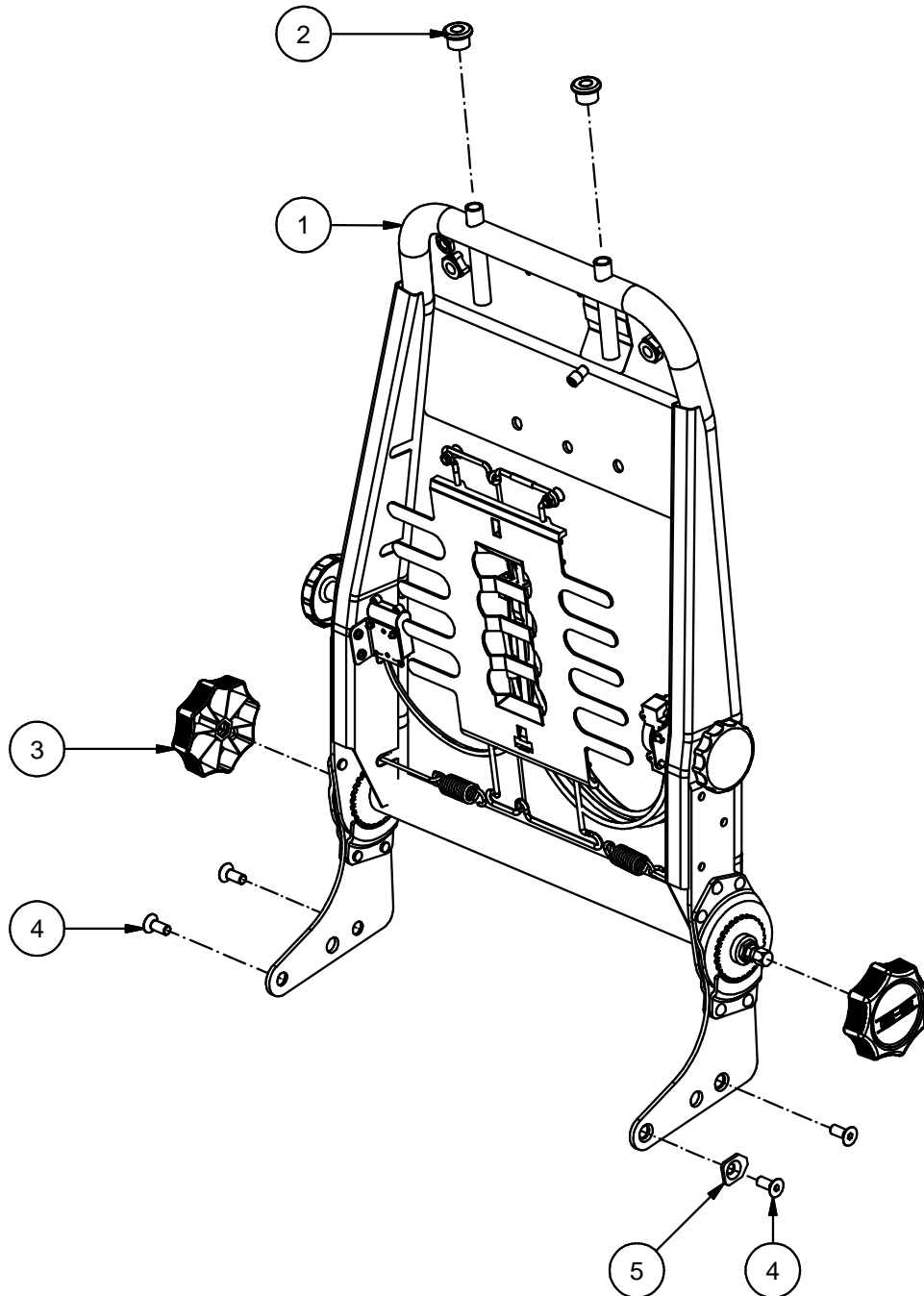

Fig.	Part. No.	Quantity	Description		
1	628099	1	BACKREST CPL 640 9000		
2	500385	2	HEADREST GROMMET		
3	621408	2	HAND WHEEL M10		
4	310930	4	SCREW MF6S	M8x20	DIN7991 ZN-BL 10.9
5	620143	1	EXCENTER WASHER		



Parts Replacements List

628885
BACK FRAME 640QR
9000

Valid from 051104 to

Doc. R1-628885

Date 120608

Rev. 0

Rev.Date

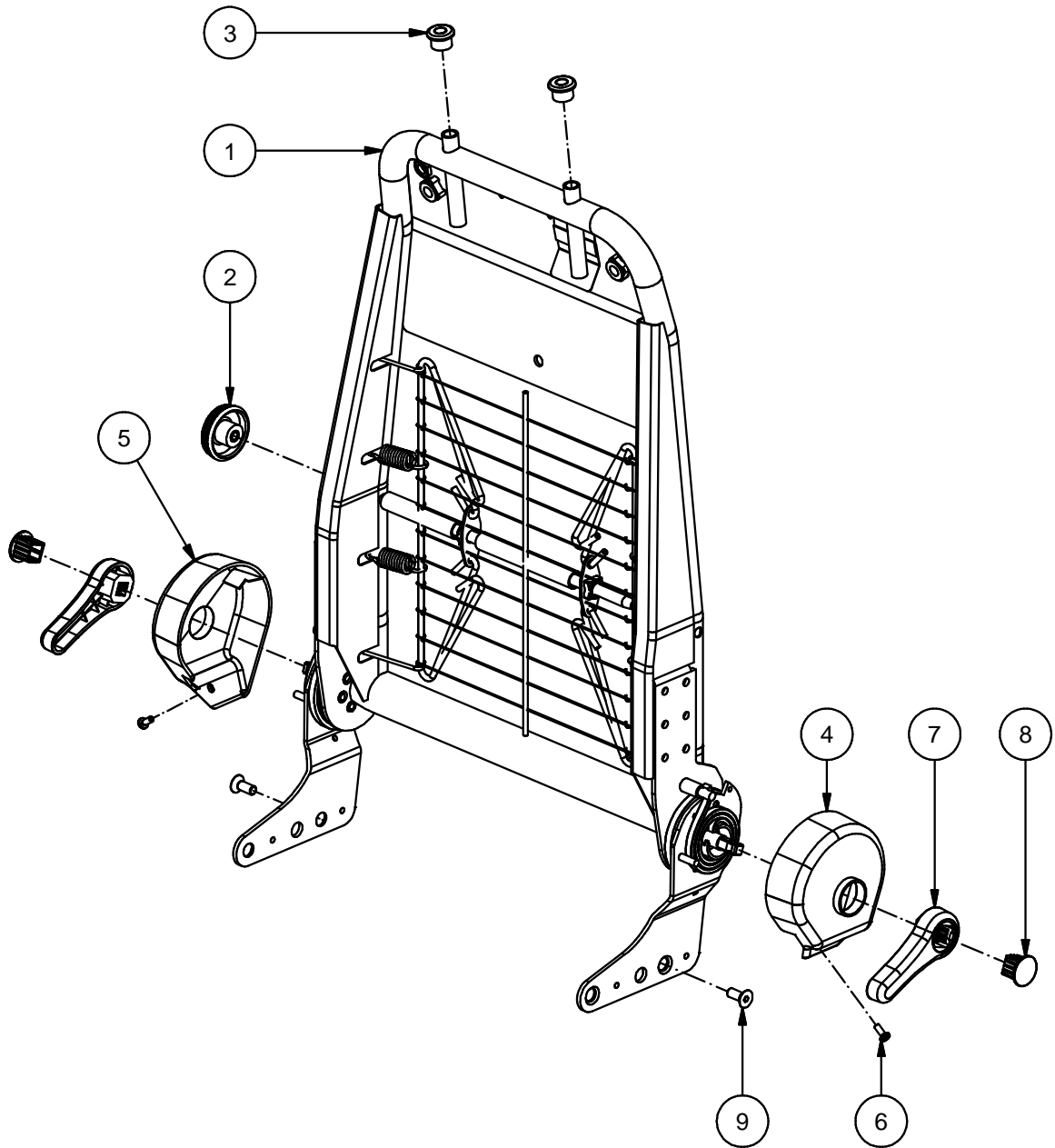

Fig.	Part. No.	Quantity	Description		
1	628864	1	BACKFRAME 640 QR		
2	500279	1	HANDWHEEL M8		
3	500385	2	HEADREST GROMMET		
4	628831	1	COVER LEFT		
5	628832	1	COVER RIGHT		
6	650126	2	SCREW MRT-TT	M5x12	ISO7045 ZN BLACK
7	628833	2	GRIP		
8	628834	2	CAP GRIP		
9	310930	2	SCREW MF6S	M8x20	DIN7991 ZN-BL 10.9



Parts Replacements List

629151
BACK FRAME 640QR 4-WAY LS
9000

Valid from 060607 to

Doc. R1-629151

Date 120608

Rev. 0

Rev.Date

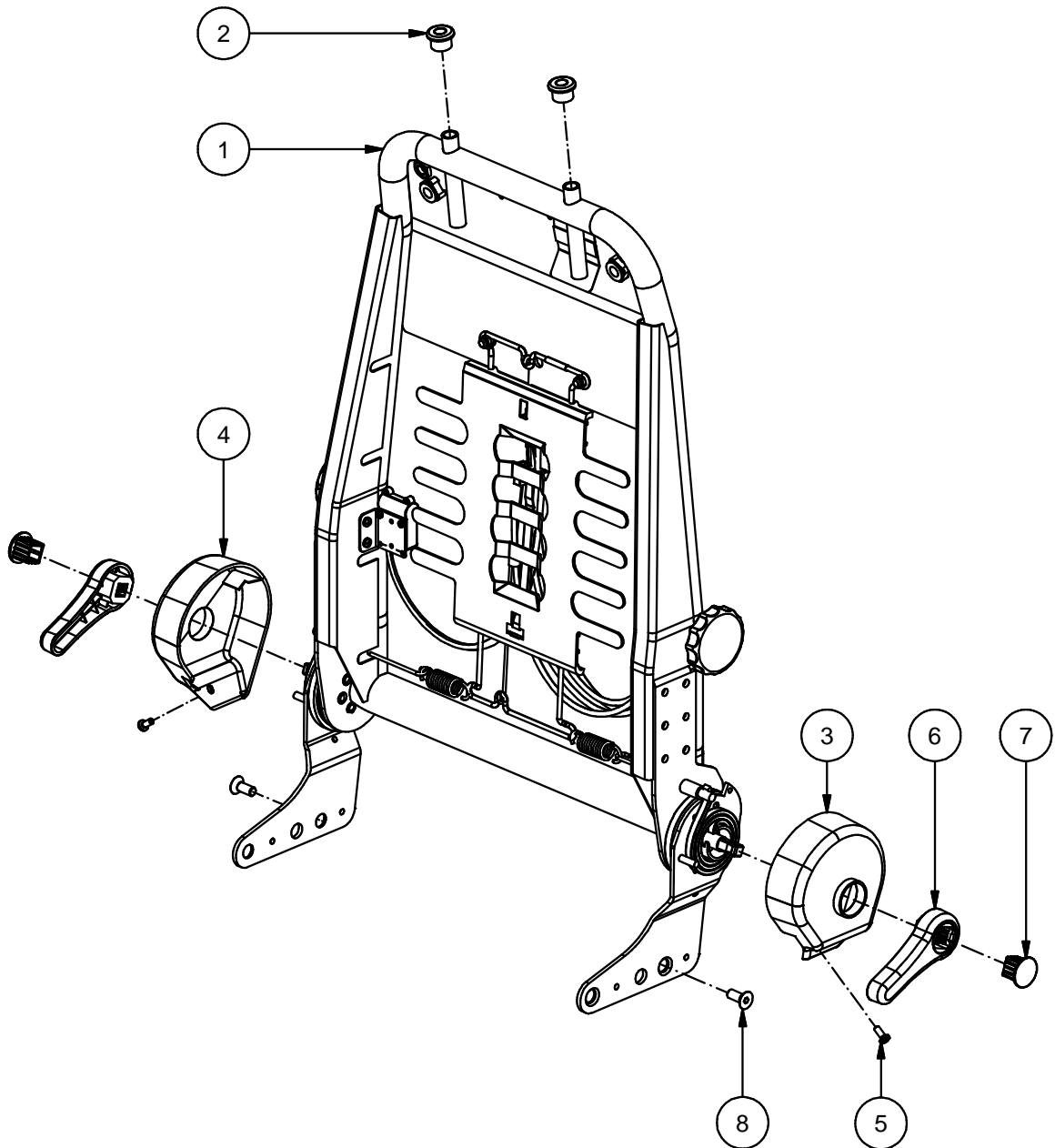

Fig.	Part. No.	Quantity	Description		
1	629005	1	ASSEMBLE BACKREST 640 QR		
2	500385	2	HEADREST GROMMET		
3	628831	1	COVER LEFT		
4	628832	1	COVER RIGHT		
5	650126	2	SCREW MRT-TT	M5x12	ISO7045 ZN BLACK
6	628833	2	GRIP		
7	628834	2	CAP GRIP		
8	310930	2	SCREW MF6S	M8x20	DIN7991 ZN-BL 10.9



Parts Replacements List

603094

**EQUIPMENT KIT BUILT-IN COMPRESSOR 24V
7000**

Valid from 050216 to

Doc. R1-603094

Date 081001

Rev.

Rev.Date

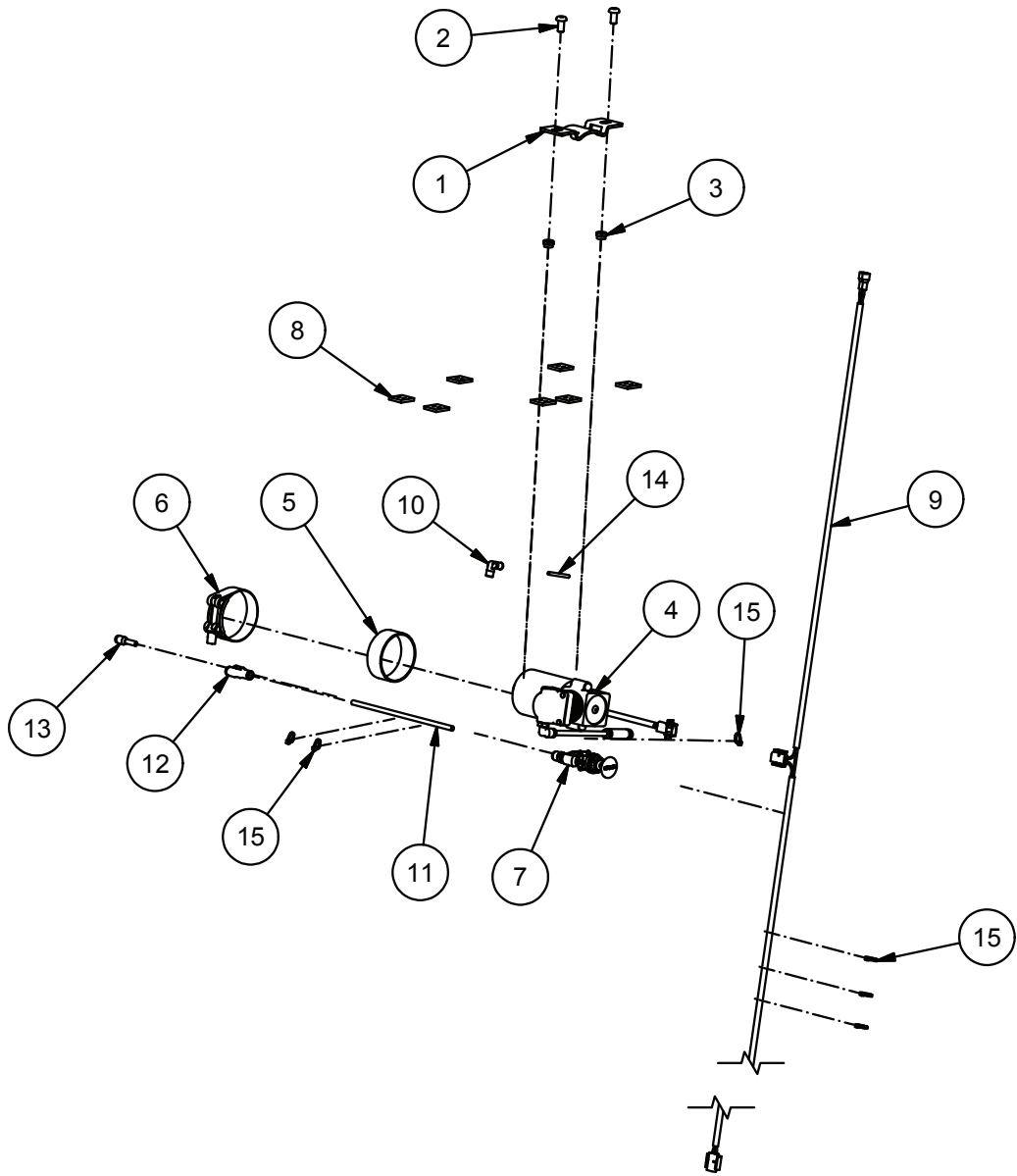

Fig.	Part. No.	Quantity	Description		
1	628679	1	BRACKET		
2	650021	2	SCREW K6S	M8x16	ISO7380 ZN-BL 10.9
3	210401	2	LOCKING NUT	M8	DIN6925 ZN K8
4	500666	1	COMPRESSOR 24V		
5	628681	1	RUBBER STRIP		
6	628680	1	HOSE CLIP		
7	621080	1	GT VALVE		
8	501120	7	FOAM RUBBER		
9	628706	1	CABLE HARNESS		
10	660397	1	ONE TOUCH FITTING ELBOW	4-1/8	
11	500211	0.65 LPM	PLASTIC TUBING	6/4	DIN74324 BLACK
12	660386	1	SLIP IN COUPLING	Y6	
13	660387	1	SLIP IN COUPLING	6-4	
14	660388	0.66 LPM	PLASTIC TUBING	4/2.5	DIN73378 BLACK
15	500317	6	CABLE TIE	200x4.6	WHITE



Parts Replacements List

620670
BELT KIT 3P LEFT
9000

Valid from 920504 to

Doc. R1-620670

Date 120608

Rev. 0

Rev.Date

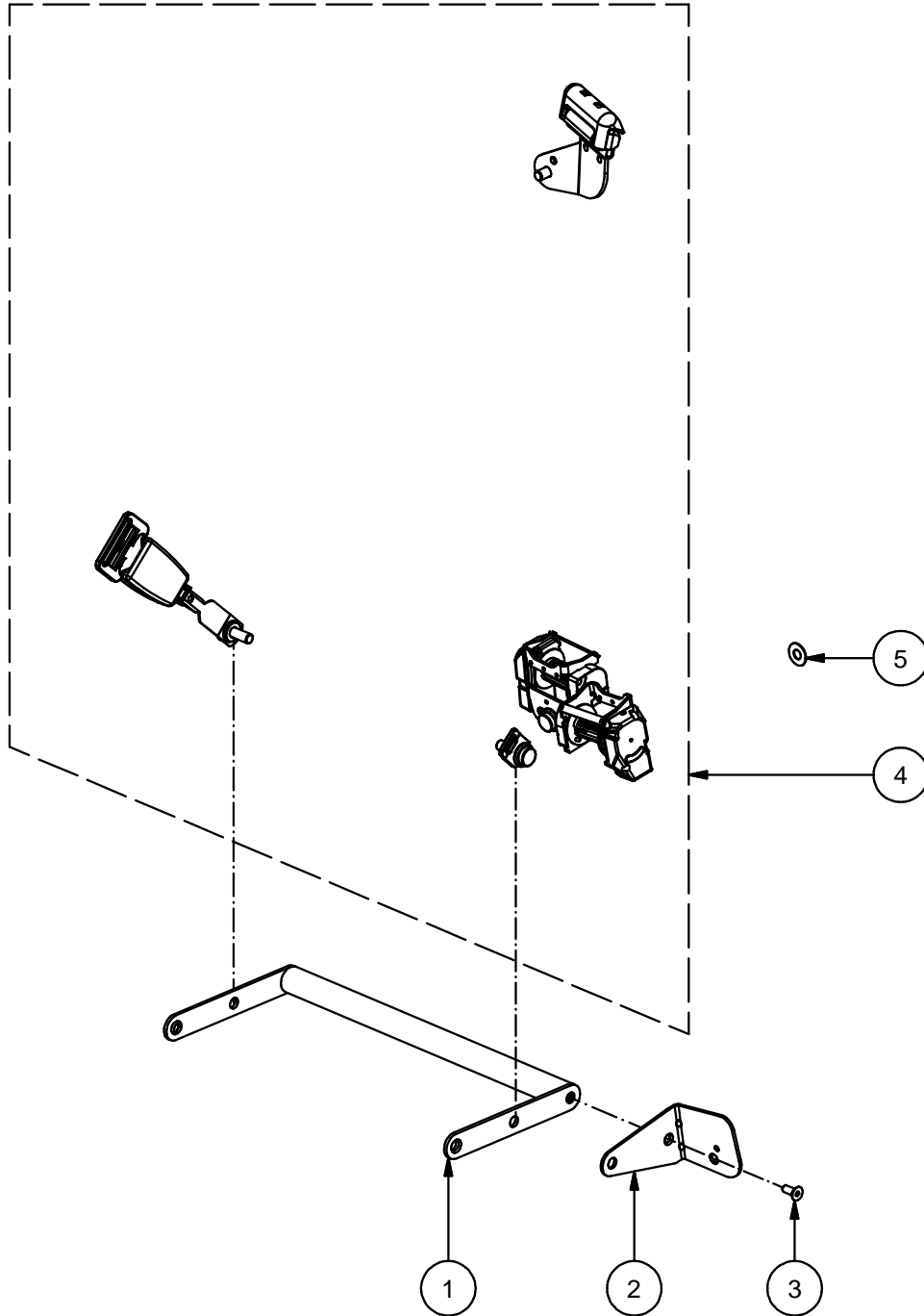

Fig.	Part. No.	Quantity	Description		
1	620074	1	YOKE		
2	620077	1	BRACKET LEFT		
3	310930	1	SCREW MF6S	M8x20	DIN7991 ZN-BL 10.9
4	620086	1	SAFETY BELT 3P LH		
5	652020	1	WASHER	11.2x26x1.0	ZN YELLOW



Parts Replacements List

620090
SLIDE KIT 3P-BELT
9000

Valid from 890526 to

Doc. R1-620090

Date 100506

Rev.

Rev.Date

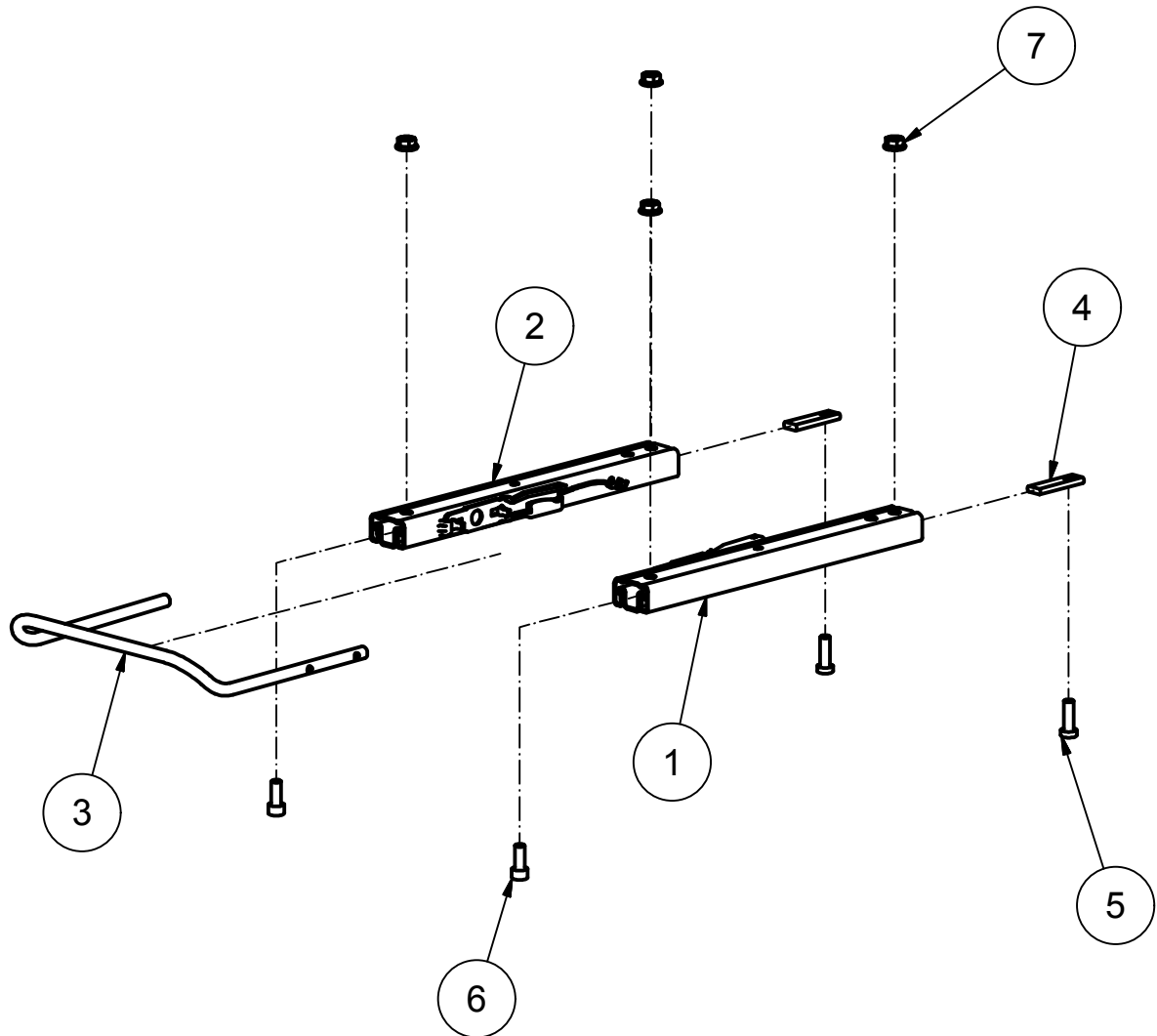

Fig.	Part. No.	Quantity	Description		
1	501212	1	SLIDE RAIL LEFT		
2	501211	1	SLIDE RAIL RIGHT		
3	620093	1	CLAMP BELT SEAT		
4	620089	2	REINFORCEMENT		
5	650017	2	SCREW MC6LS	M8x25	DIN7984 ZN 8.8
6	500302	2	SCREW MC6S	M8x20	DIN912 ZN 8.8
7	651054	4	NUT TENSIFLANGE	M8	DIN6923 ZN K8



Parts Replacements List

603061
SLIDE RAIL KIT 3PB 4° TILT
9000

Valid from 970908 to

Doc. R1-603061

Date 120608

Rev. 0

Rev.Date

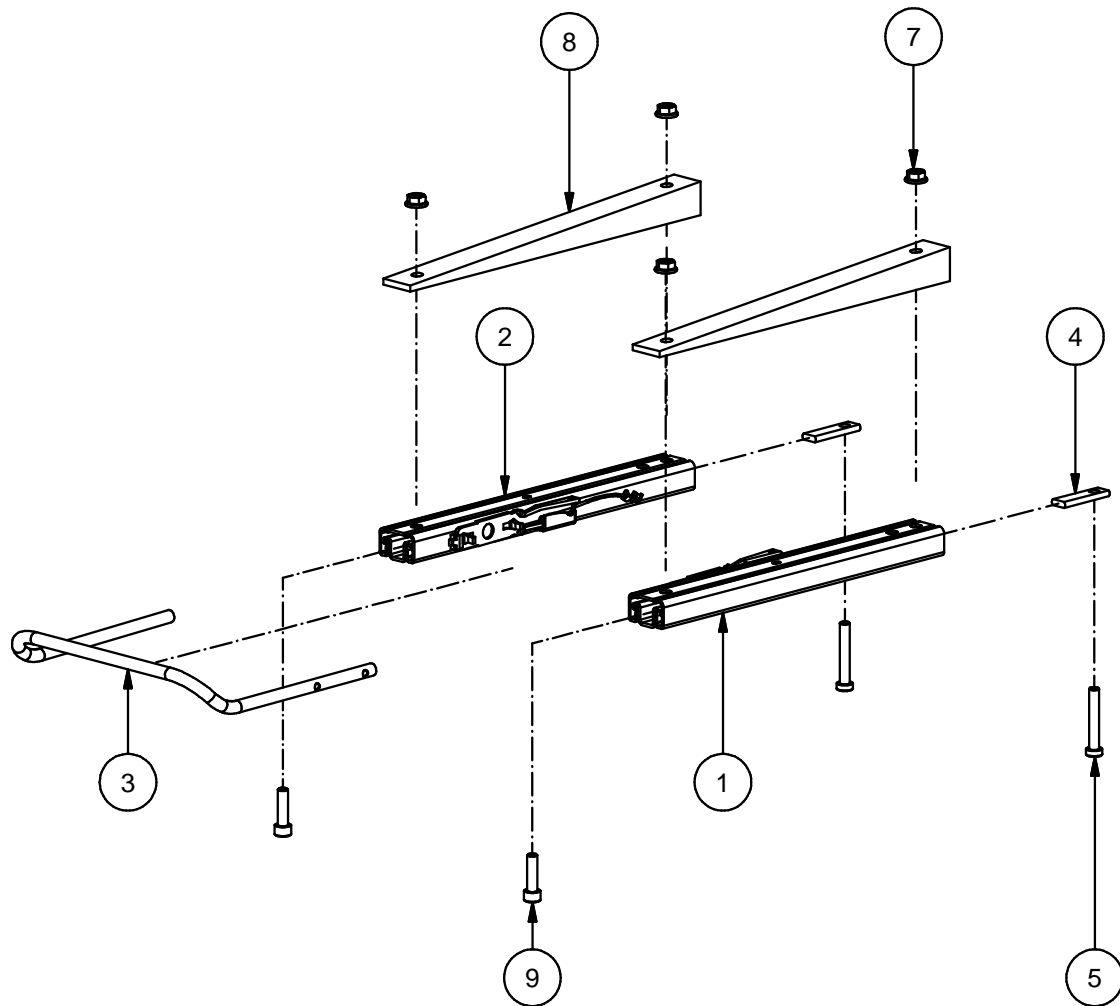

Fig.	Part. No.	Quantity	Description		
1	501212	1	SLIDE RAIL LEFT		
2	501211	1	SLIDE RAIL RIGHT		
3	620093	1	CLAMP BELT SEAT		
4	620089	2	REINFORCEMENT		
5	650084	2	SCREW MC6LS	M8x50	DIN7984 ZN 8.8
7	651054	4	NUT TENSIFLANGE	M8	DIN6923 ZN K8
8	500895	2	LEANING SPACER 4°		
9	650040	2	SCREW MC6S	M8 x 30	DIN 912



Parts Replacements List

603064
SLIDE RAIL KIT 3PB 8° TILT
9000

Valid from 970908 to

Doc. R1-603064

Date 120611

Rev. 0

Rev.Date

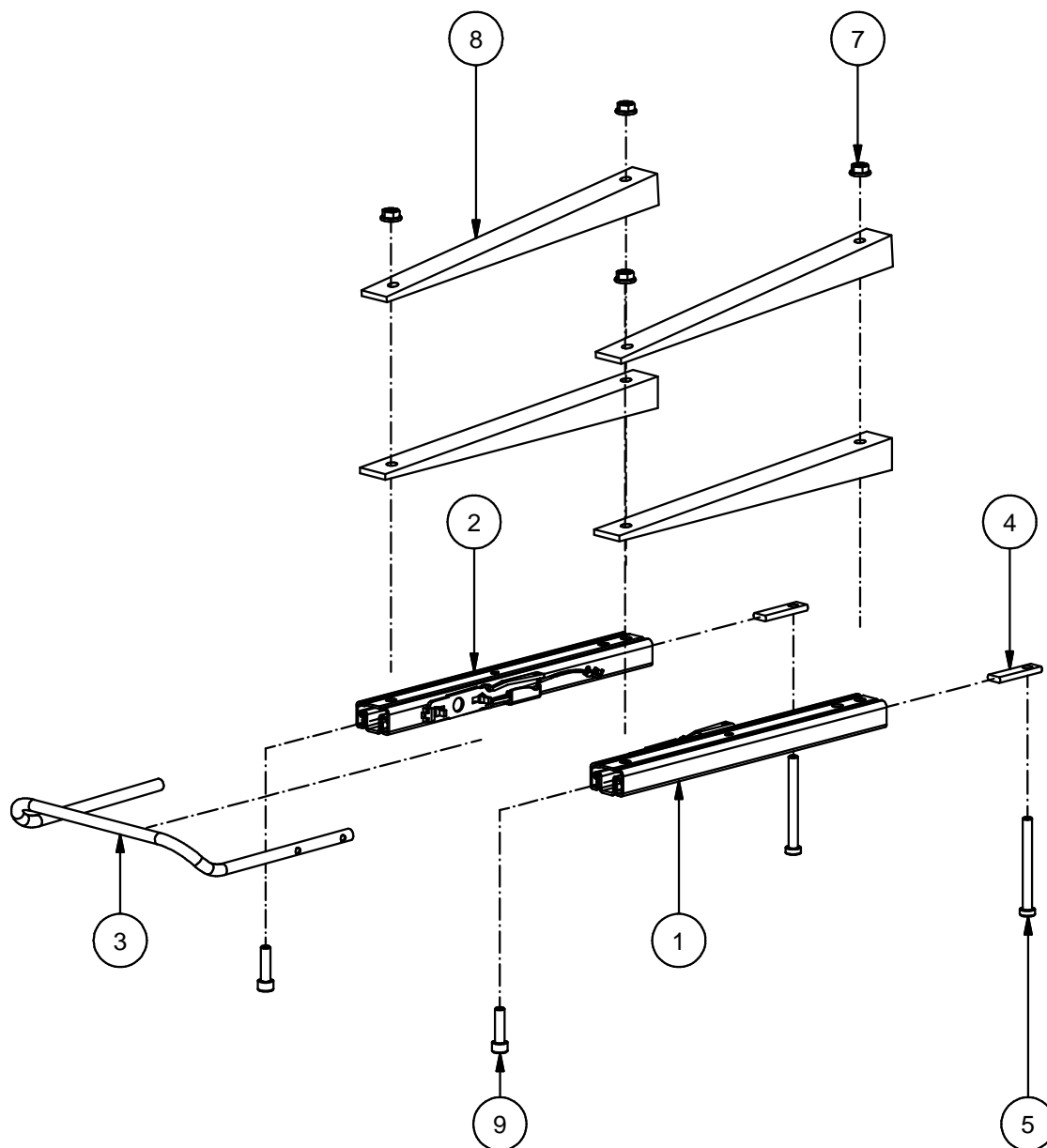

Fig.	Part. No.	Quantity	Description		
1	501212	1	SLIDE RAIL LEFT		
2	501211	1	SLIDE RAIL RIGHT		
3	620093	1	CLAMP BELT SEAT		
4	620089	2	REINFORCEMENT		
5	650085	2	SCREW MC6LS	M8x80	DIN7984 ZN 8.8
7	651054	4	NUT TENSIFLANGE	M8	DIN6923 ZN K8
8	500895	4	LEANING SPACER 4°		
9	650040	2	SCREW MC6S	M8 x 30	DIN 912



Parts Replacements List

500160
PROTECTIVE BELLOWS
9000

Valid from 840101 to

Doc. R1-500160

Date 080610

Rev.

Rev.Date

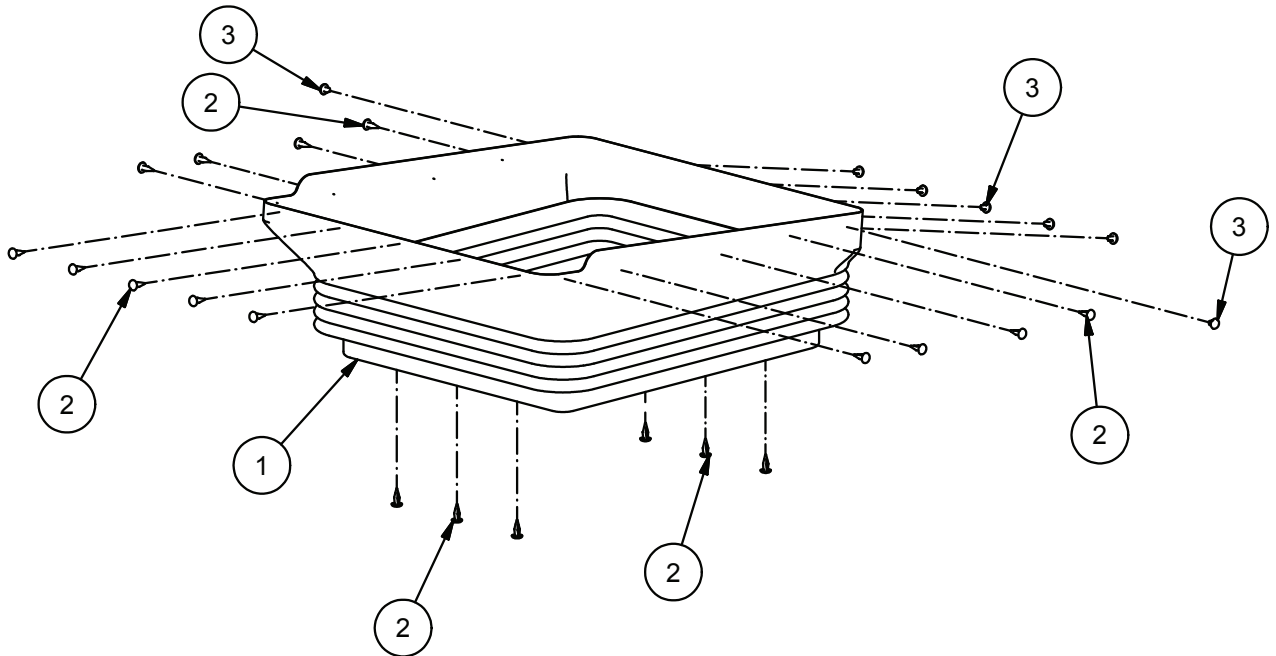

Fig.	Part. No.	Quantity	Description
1	501460	1	PROTECTIVE BELLOWS
2	500214	19	PLASTIC RIVET
3	629007	7	PLASTIC RIVET



Parts Replacements List

628571
TRIM KIT SEAT CUSHION NIGHTFALL
9000

Valid from 040501 to

Doc. R1-628571

Date 081124

Rev.

Rev.Date

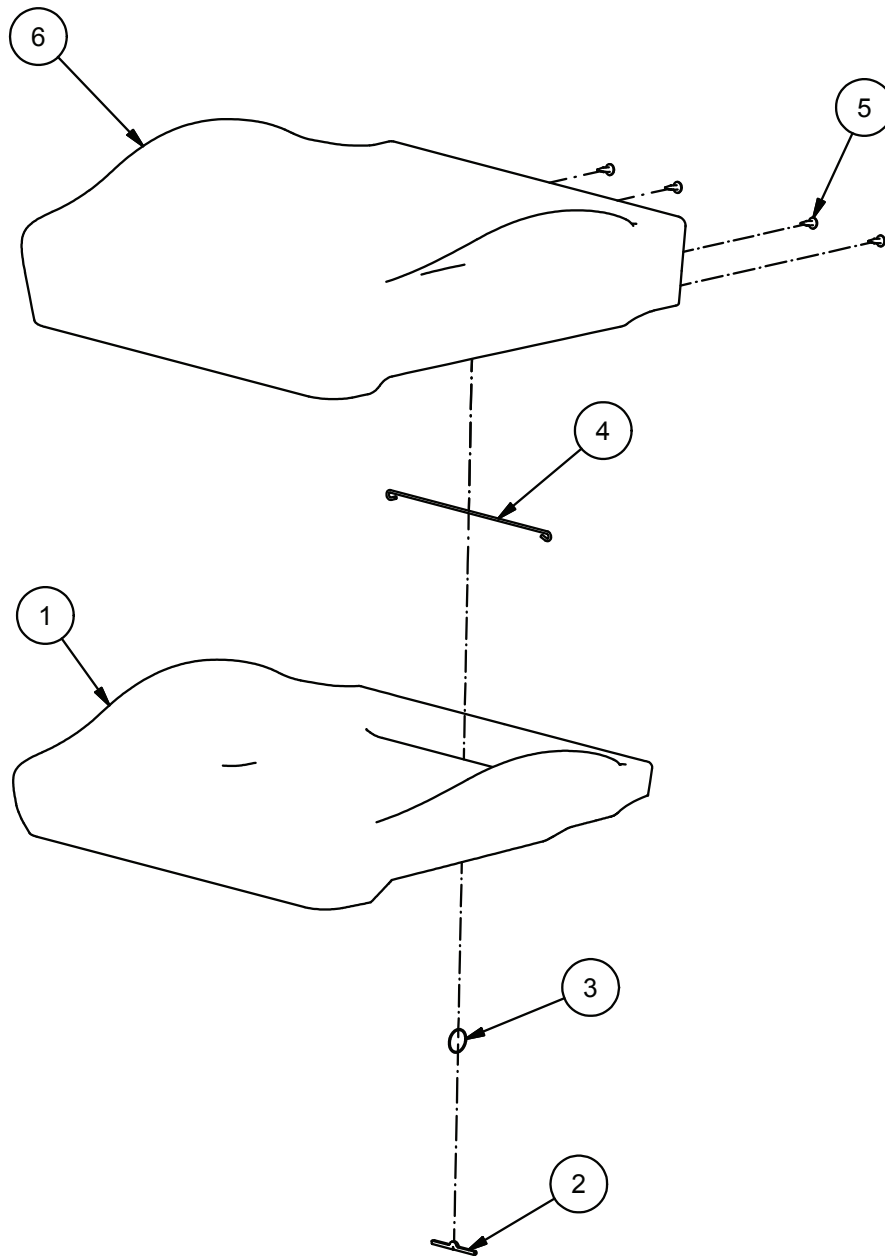

Fig.	Part. No.	Quantity	Description
1	500190	1	FOAM CUSHION
2	621404	1	BARETT PIN
3	660057	1	LOOPS 30 MM
4	620140	1	BRACKET L=230
5	500214	4	PLASTIC RIVET
6	641329	1	TRIM CUSHION

NIGHTFALL



Parts Replacements List

628572

TRIM KIT SEAT CUSHION CT NIGHTFALL

9000

Valid from 040501 to

Doc. R1-628572

Date 110428

Rev. 0

Rev.Date

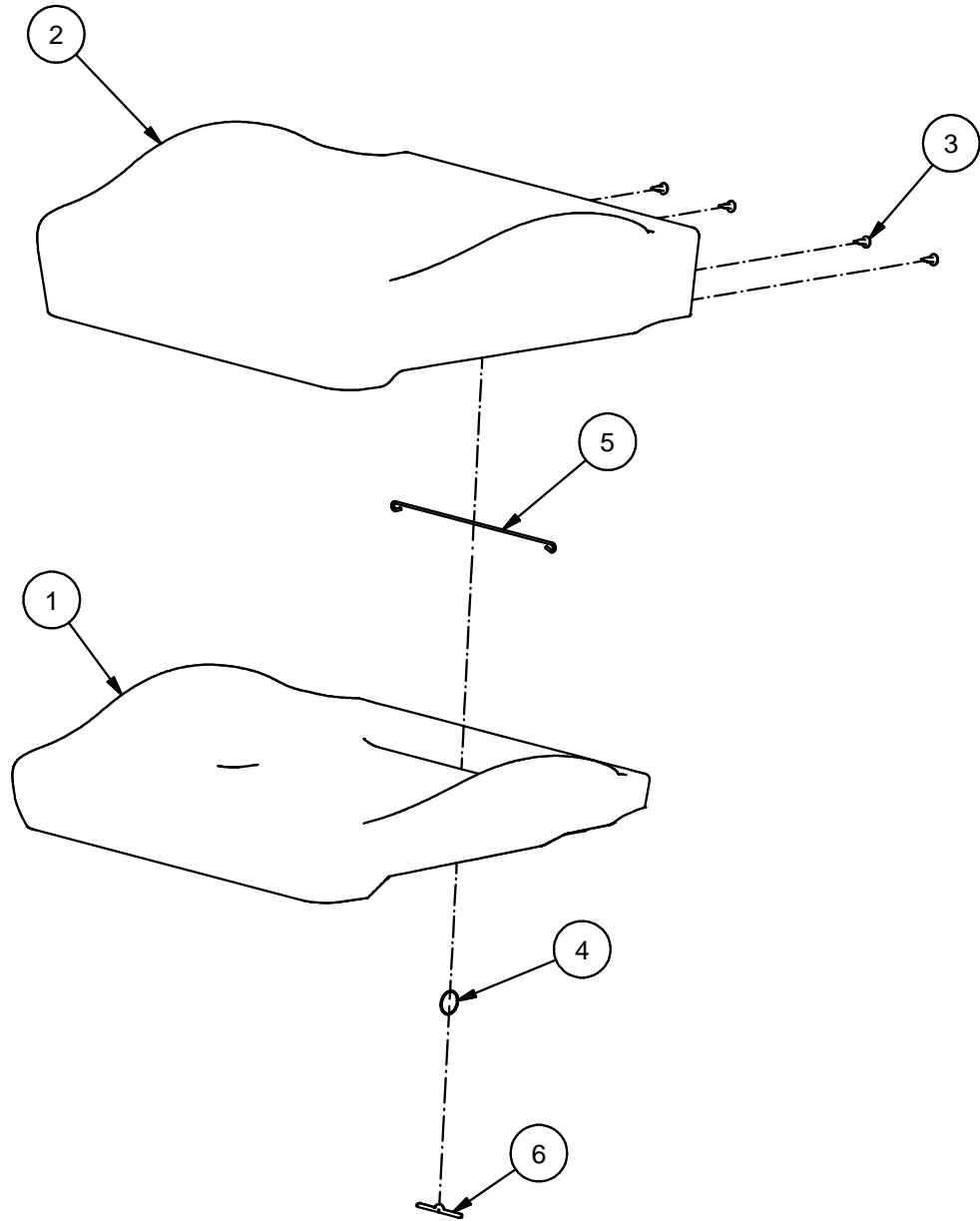

Fig.	Part. No.	Quantity	Description
1	500189	1	FOAM CUSHION
2	641329	1	TRIM CUSHION
3	500214	4	PLASTIC RIVET
4	660057	1	LOOPS 30 MM
5	620140	1	BRACKET L=230
6	621404	1	BARETT PIN



Parts Replacements List

628574

**TRIM KIT SEAT EPN NIGHTFALL
7130LC4**

Valid from 110302 to

Doc. R1-628574

Date 110302

Rev. 0

Rev.Date

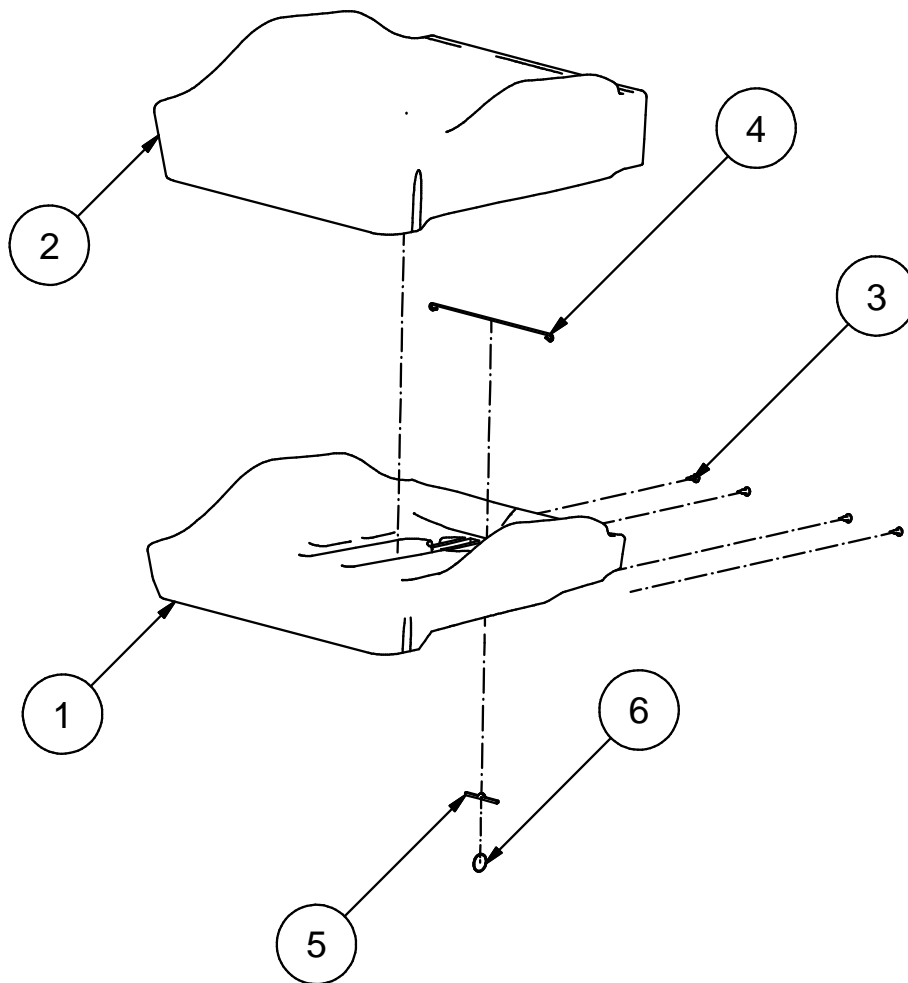

1	621388	1	FOAM CUSHION		
2	641330	1	TRIM SEAT		
3	500214	4	PLASTIC RIVET		
4	620140	1	BRACKET L=230		
5	621404	1	BARRET PIN		
6	660057	1	LOOPS 30MM		



Parts Replacements List

620313

**TRIM KIT SEAT CUSHION ART. LEATHER GREY
9000**

Valid from 900810 to

Doc. R1-620313

Date 120509

Rev. 0

Rev.Date

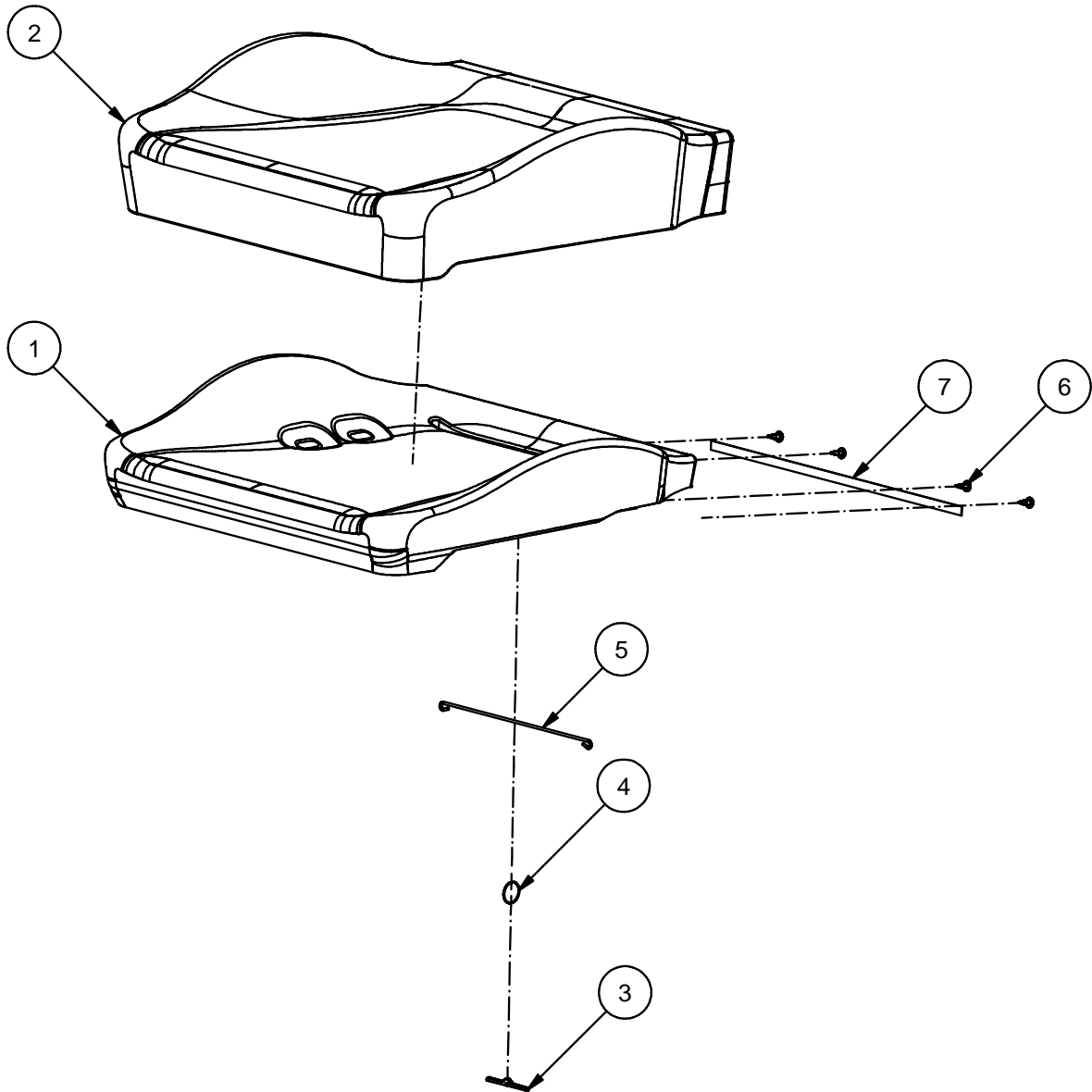

Fig.	Part. No.	Quantity	Description		
1	500190	1	FOAM CUSHION		
2	500958	1	TRIM CUSHION		ART. LEATHER GREY
3	621404	1	BARETT PIN		
4	660057	1	LOOPS 30 MM		
5	620140	1	BRACKET L=230		
6	500214	4	PLASTIC RIVET		
7	500281	1	PLASTIC STRIP		



Parts Replacements List

620319

**TRIM KIT SEAT CUSHION CT ART. LEA. GREY
9000**

Valid from 900810 to

Doc. R1-620319

Date 120509

Rev. 0

Rev.Date

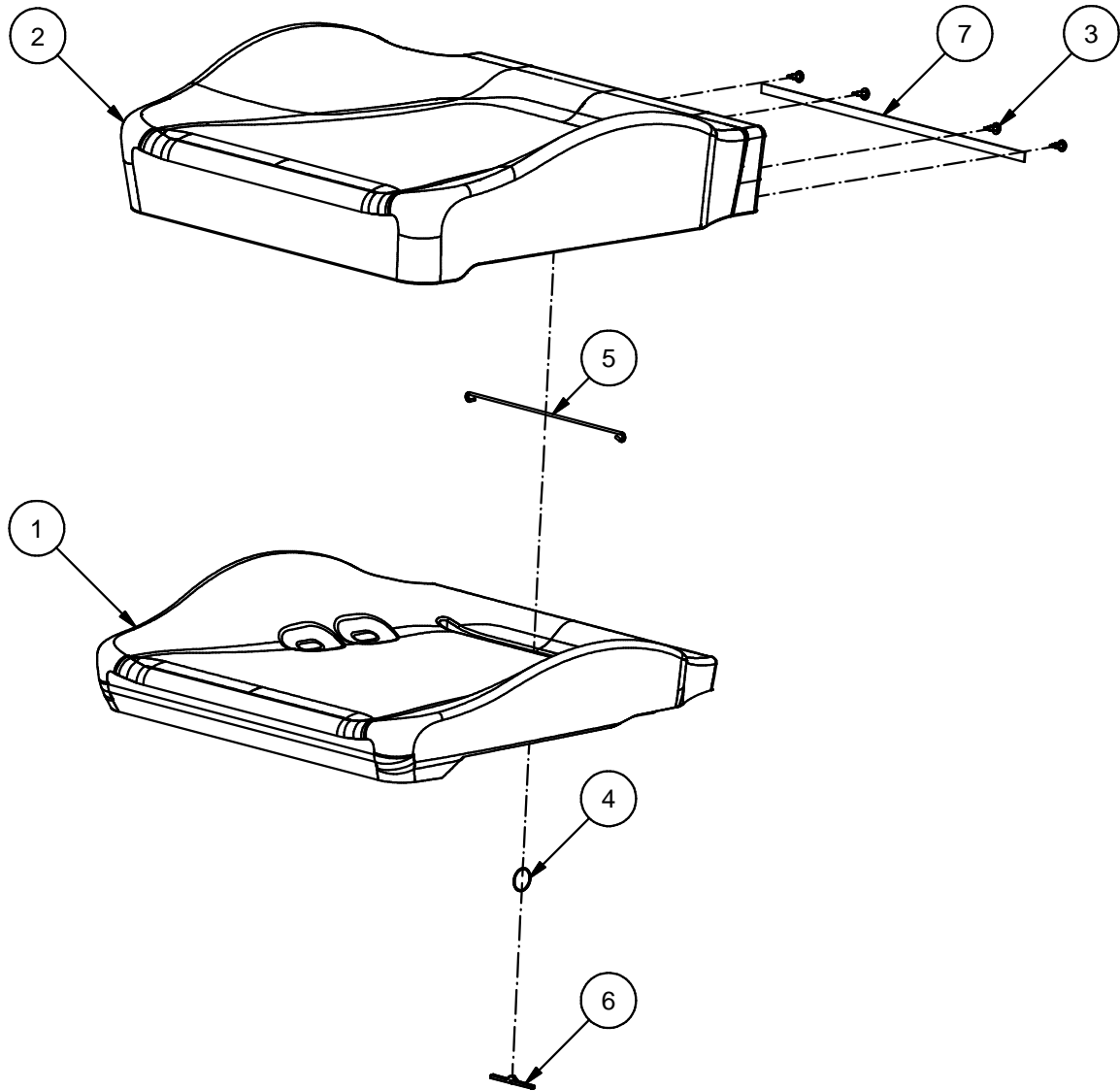

Fig.	Part. No.	Quantity	Description		
1	500189	1	FOAM CUSHION		
2	500958	1	TRIM CUSHION		ART. LEATHER GREY
3	500214	4	PLASTIC RIVET		
4	660057	1	LOOPS 30 MM		
5	620140	1	BRACKET L=230		
6	621404	1	BARETT PIN		
7	500281	1	PLASTIC STRIP		



Parts Replacements List

620323

**TRIM KIT SEAT CUSHION LEATHER GREY
9000**

Valid from 900810 to

Doc. R1-620323

Date 120613

Rev. 0

Rev.Date

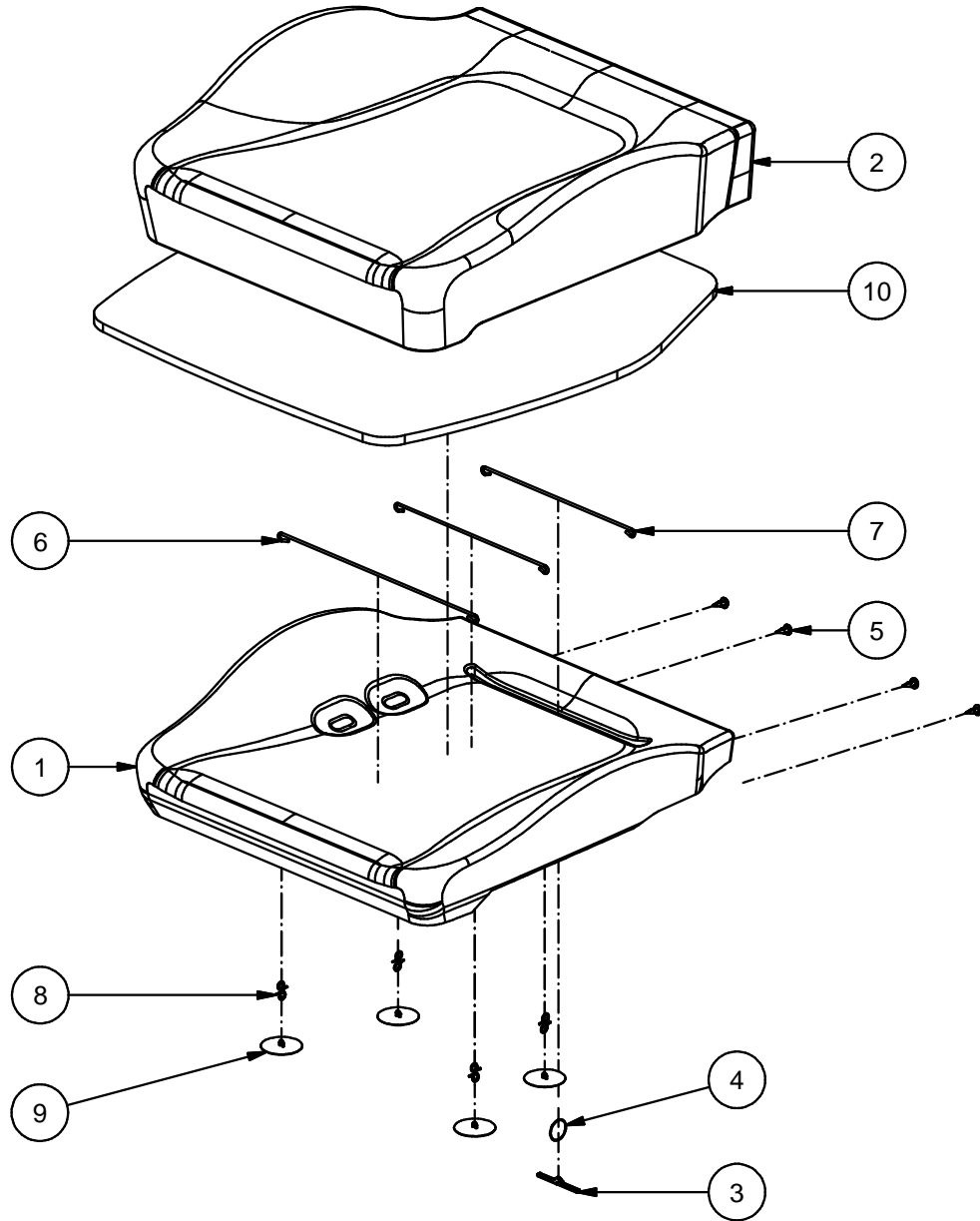

Fig.	Part. No.	Quantity	Description		
1	500190	1	FOAM CUSHION		
2	500586	1	TRIM CUSHION		LEATHER GREY BALTIQUE
3	621404	1	BARETT PIN		
4	660057	1	LOOPS 30 MM		
5	500214	4	PLASTIC RIVET		
6	620115	1	BRACKET L=300		
7	620140	2	BRACKET L=230		
8	660096	4	S-HOOK		L=22 Ø=1,5
9	500650	4	BACK BUTTON		Ø=22 WHITE
10	640016	1	POLYESTER WAD 10 MM SEAT		



Parts Replacements List

620329

**TRIM KIT SEAT CUSHION LEATHER GREY
9000**

Valid from 900810 to

Doc. R1-620329

Date 120613

Rev. 0

Rev.Date

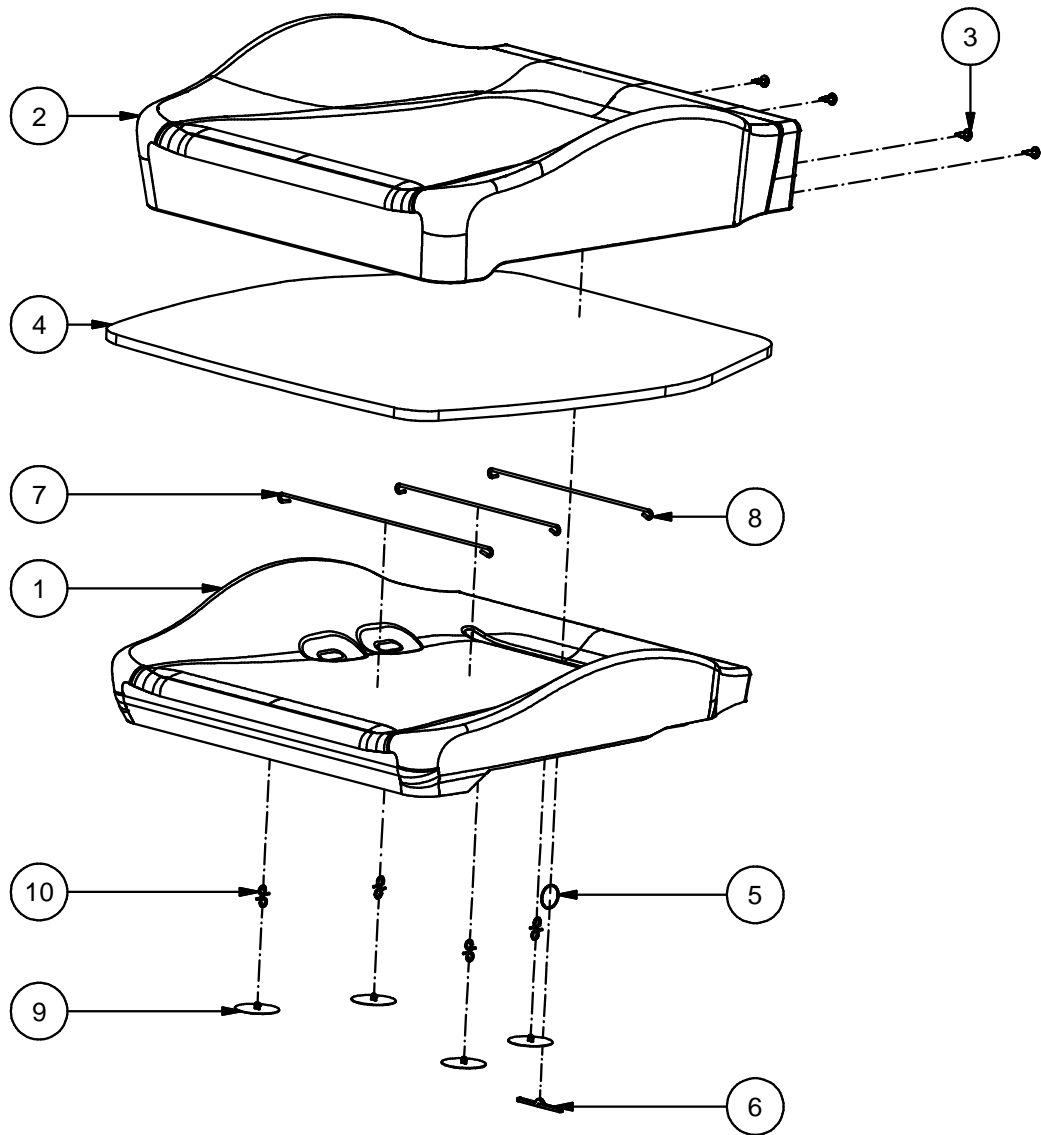

Fig.	Part. No.	Quantity	Description		
1	500189	1	FOAM CUSHION		
2	500586	1	TRIM CUSHION		LEATHER GREY BALTIQUE
3	500214	4	PLASTIC RIVET		
4	640016	1	POLYESTER WAD 10 MM SEAT		
5	660057	1	LOOPS 30 MM		
6	621404	1	BARETT PIN		
7	620115	1	BRACKET L=300		
8	620140	2	BRACKET L=230		
9	500650	4	BACK BUTTON		Ø=22 WHITE
10	660096	4	S-HOOK		L=22 Ø=1,5



Parts Replacements List

620903

**TRIM KIT SEAT CUSHION PLUSH BLUE 84
9000**

Valid from 930208 to

Doc. R1-620903

Date 120509

Rev. 0

Rev.Date

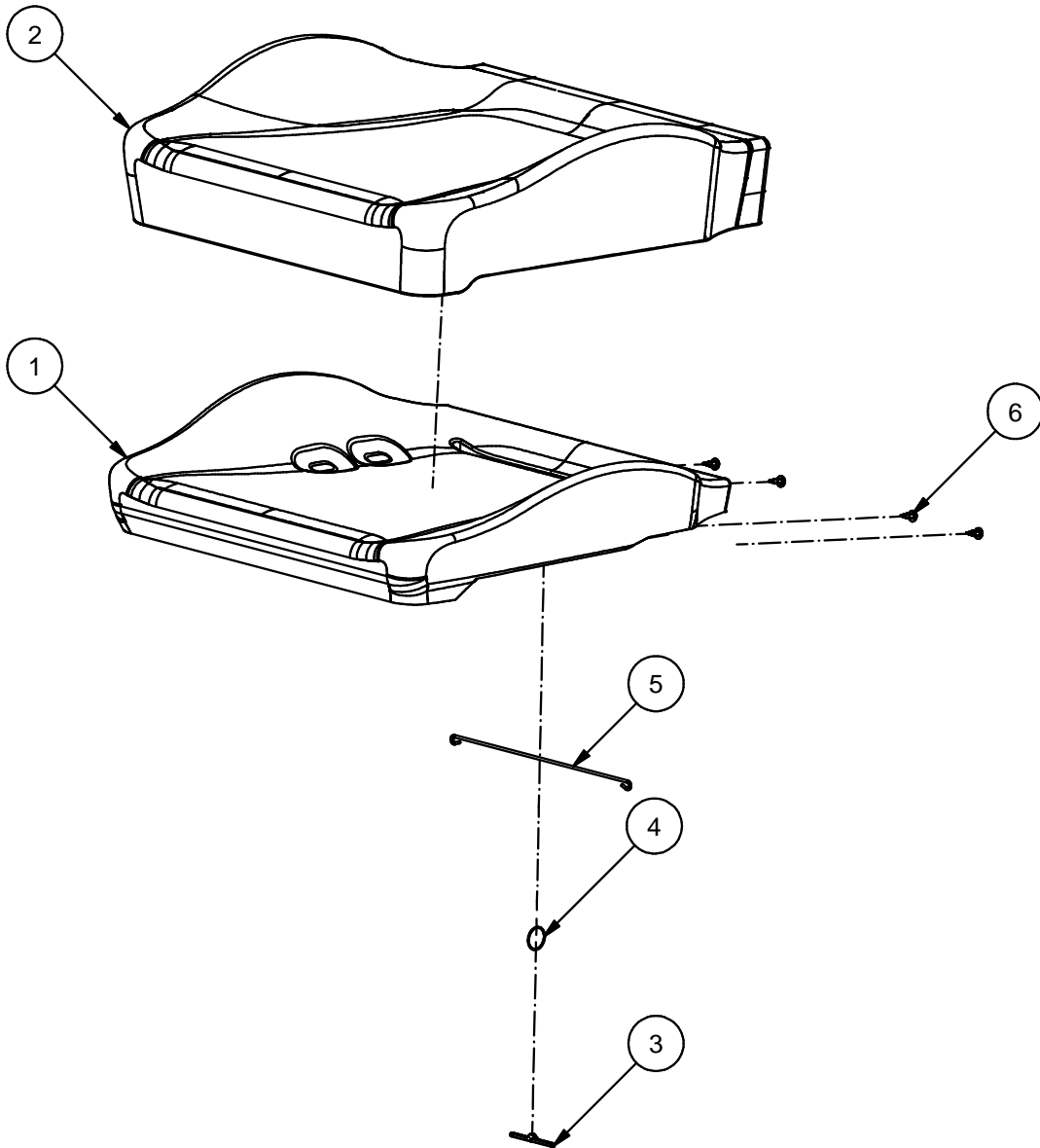

Fig.	Part. No.	Quantity	Description
1	500190	1	FOAM CUSHION
2	640315	1	TRIM CUSHION
3	621404	1	BARETT PIN
4	660057	1	LOOPS 30 MM
5	620114	1	BRACKET L=260
6	500214	4	PLASTIC RIVET



Parts Replacements List

620909

**TRIM KIT SEAT CUSHION CT PLUSH BLUE 84
9000**

Valid from 930208 to

Doc. R1-620909

Date 120511

Rev. 0

Rev.Date

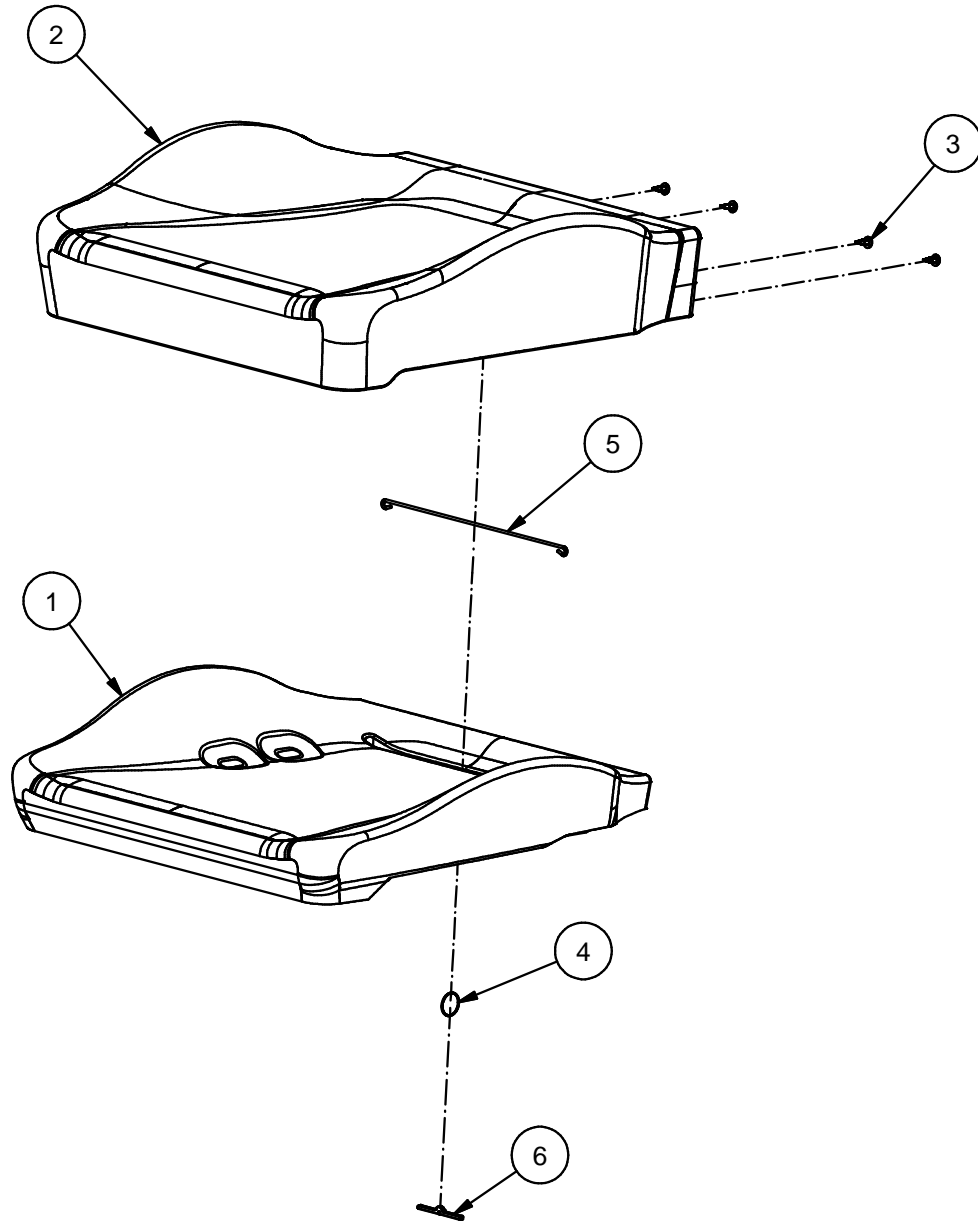

Fig.	Part. No.	Quantity	Description		
1	500189	1	FOAM CUSHION		
2	640315	1	TRIM CUSHION		PLUSH BLUE 84
3	500214	4	PLASTIC RIVET		
4	660057	1	LOOPS 30 MM		
5	620114	1	BRACKET L=260		
6	621404	1	BARETT PIN		



Parts Replacements List

620923

**TRIM KIT SEAT CUSHION PLUSH RED 82
9000**

Valid from 930208 to

Doc. R1-620923

Date 120612

Rev. 0

Rev.Date

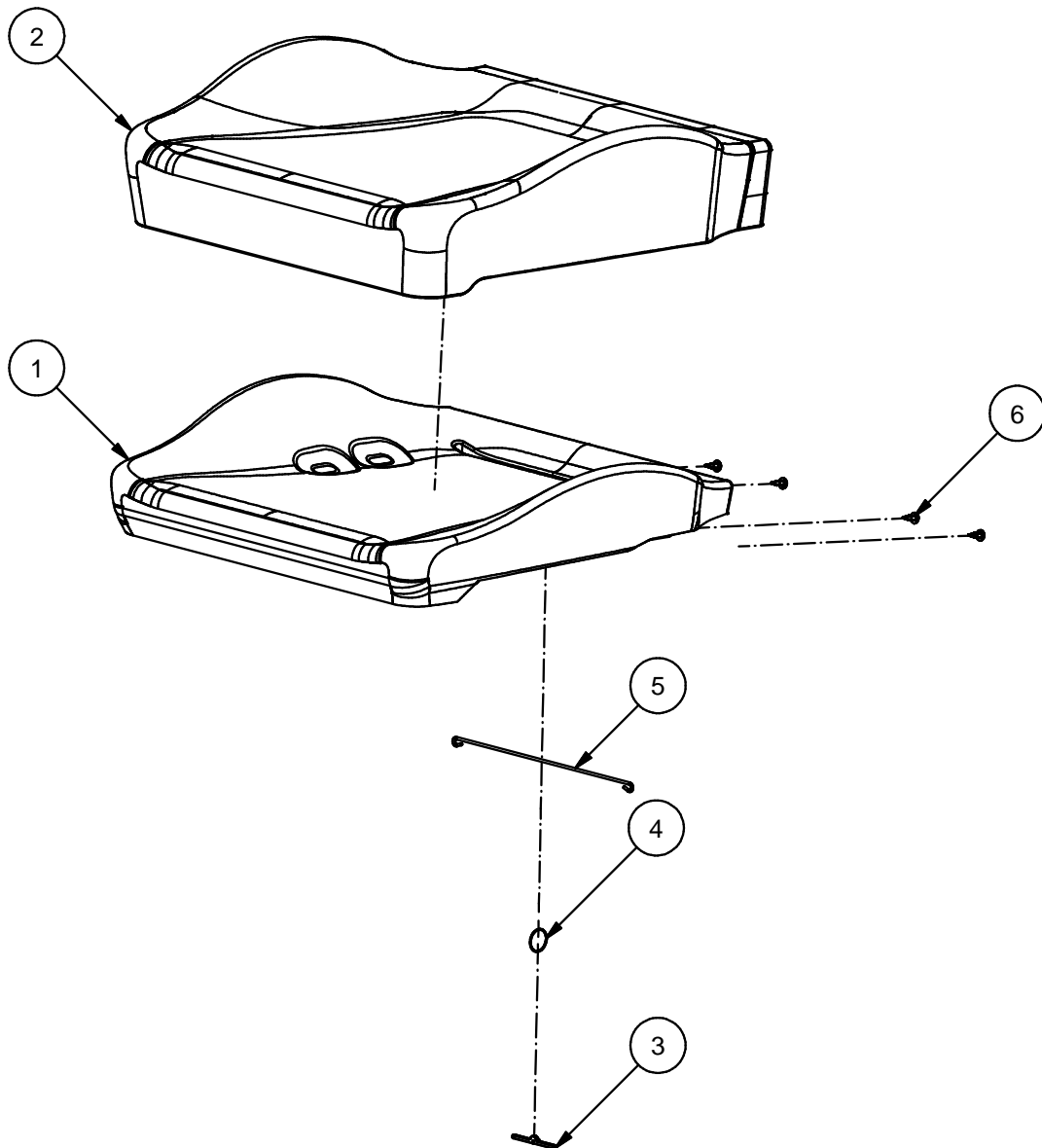

Fig.	Part. No.	Quantity	Description
1	500190	1	FOAM CUSHION
2	640275	1	TRIM CUSHION
3	621404	1	BARETT PIN
4	660057	1	LOOPS 30 MM
5	620114	1	BRACKET L=260
6	500214	4	PLASTIC RIVET



Parts Replacements List

620929

**TRIM KIT SEAT CUSHION CT PLUSH RED 82
9000**

Valid from 930208 to

Doc. R1-620929

Date 120611

Rev. 0

Rev.Date

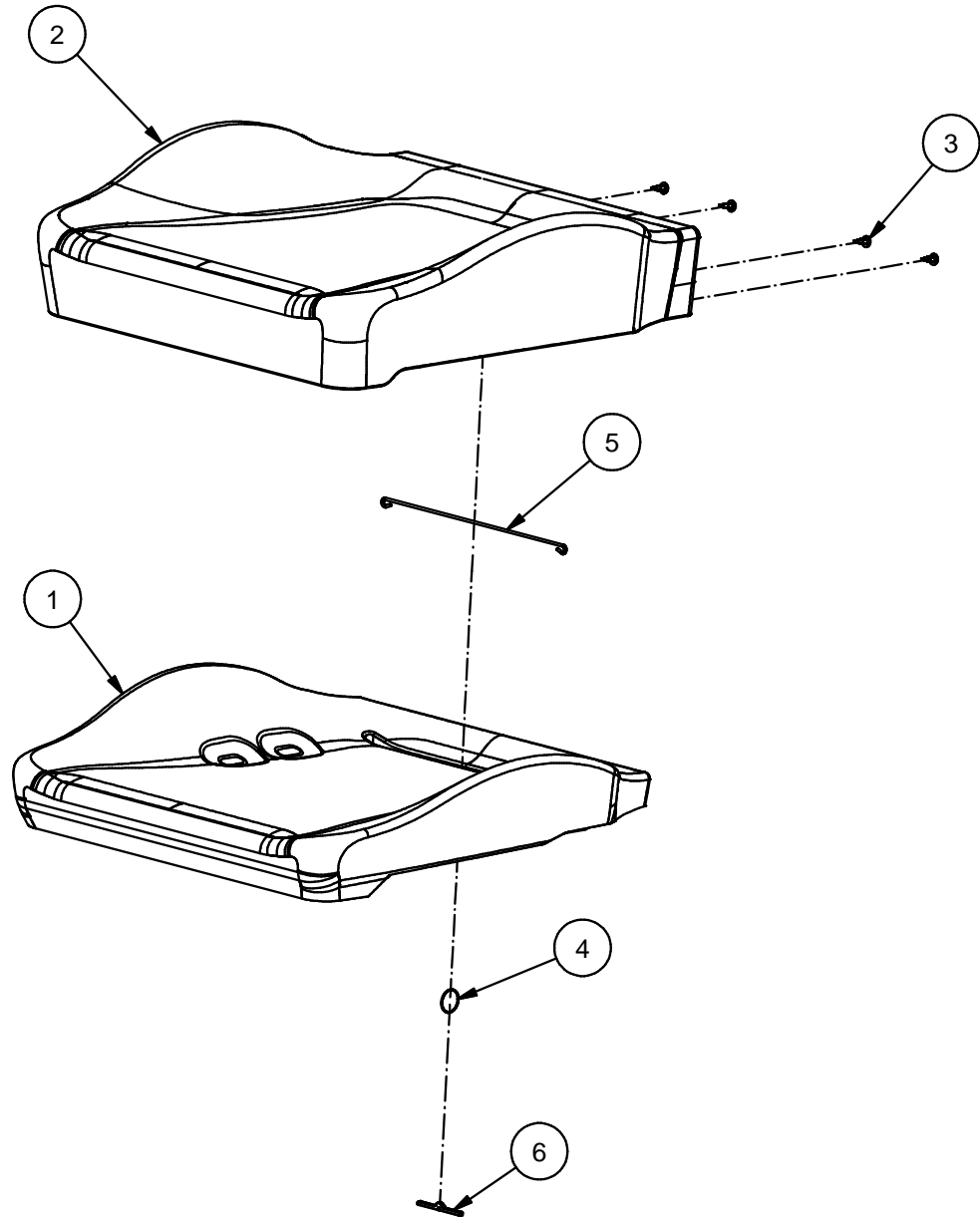

Fig.	Part. No.	Quantity	Description		
1	500189	1	FOAM CUSHION		
2	640275	1	TRIM CUSHION		PLUSH RED 82
3	500214	4	PLASTIC RIVET		
4	660057	1	LOOPS 30 MM		
5	620114	1	BRACKET L=260		
6	621404	1	BARETT PIN		



Parts Replacements List

620943

**TRIM KIT SEAT CUSHION PLUSH GREY 89
9000**

Valid from 930208 to

Doc. R1-620963

Date 120511

Rev. 0

Rev.Date

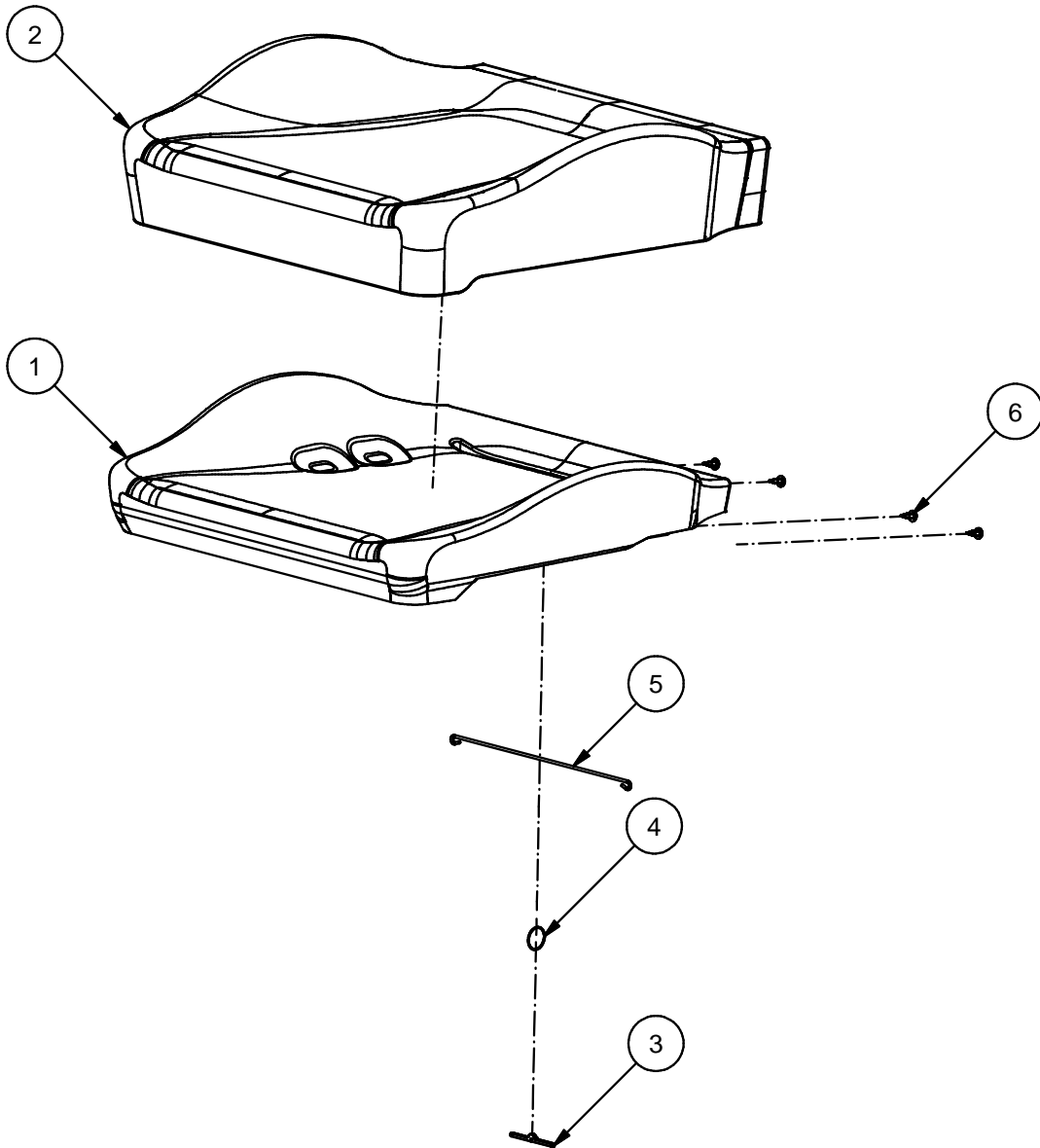

Fig.	Part. No.	Quantity	Description		
1	500190	1	FOAM CUSHION		
2	640335	1	TRIM CUSHION		PLUSH GREY 89
3	621404	1	BARETT PIN		
4	660057	1	LOOPS 30 MM		
5	620114	1	BRACKET L=260		
6	500214	4	PLASTIC RIVET		



Parts Replacements List

620949

**TRIM KIT SEAT CUSHION CT PLUSH GREY 89
9000**

Valid from 930208 to

Doc. R1-620949

Date 120511

Rev. 0

Rev.Date

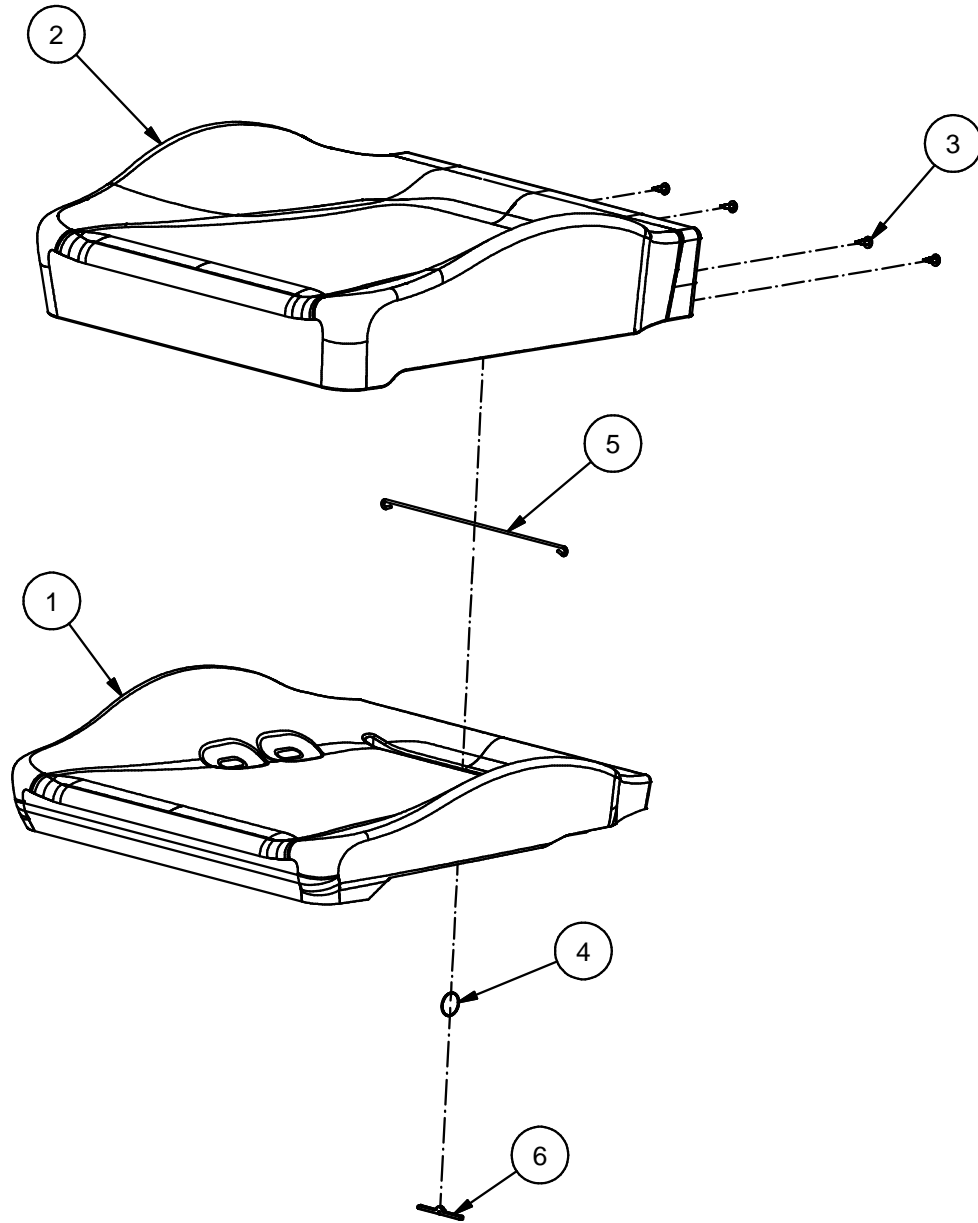

Fig.	Part. No.	Quantity	Description		
1	500189	1	FOAM CUSHION		
2	640335	1	TRIM CUSHION		PLUSH GREY 89
3	500214	4	PLASTIC RIVET		
4	660057	1	LOOPS 30 MM		
5	620114	1	BRACKET L=260		
6	621404	1	BARETT PIN		



Parts Replacements List

620963

**TRIM KIT SEAT CUSHION PLUSH BLACK 83
9000**

Valid from 930208 to

Doc. R1-620963

Date 120511

Rev. 0

Rev.Date

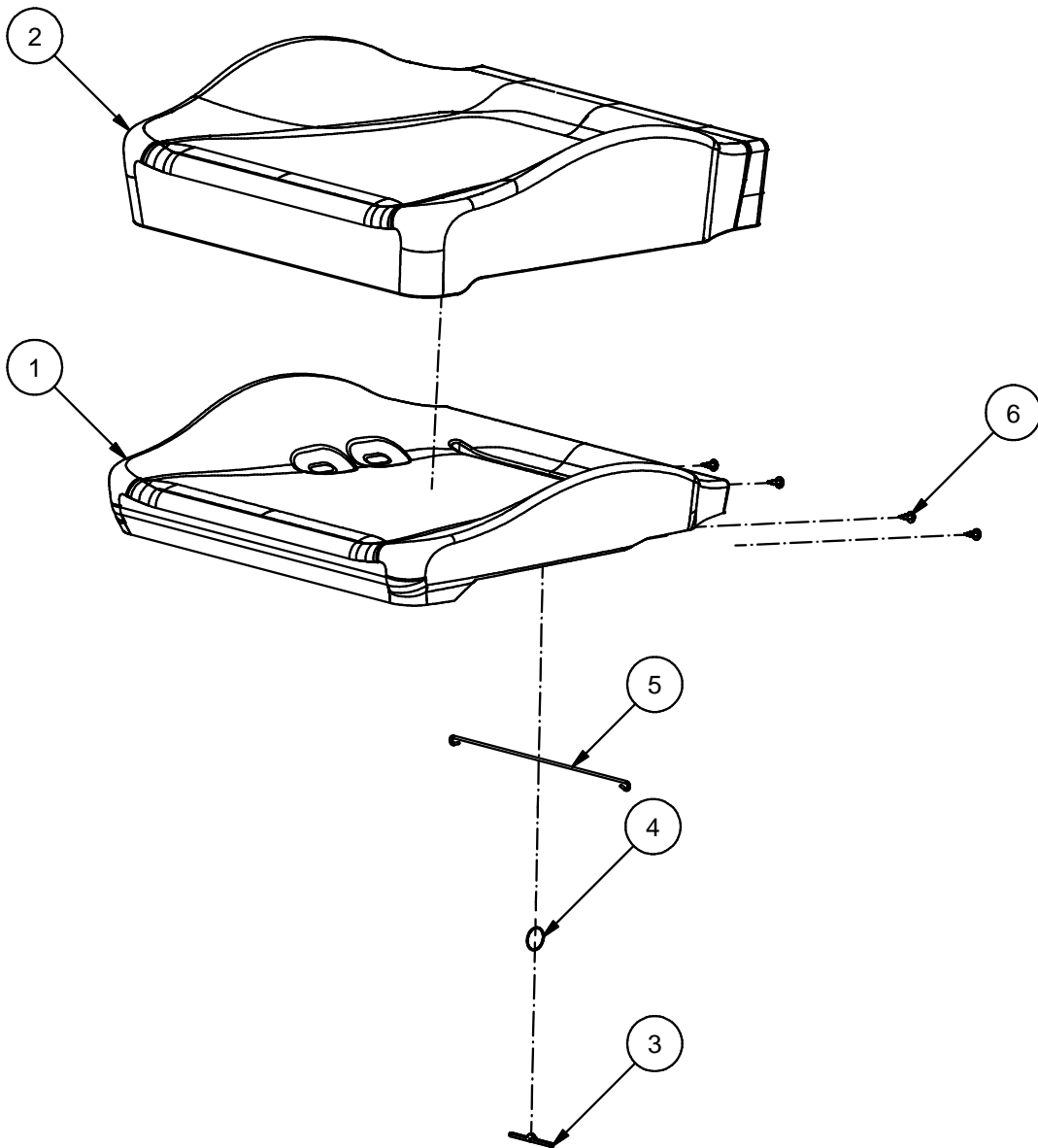

Fig.	Part. No.	Quantity	Description
1	500190	1	FOAM CUSHION
2	640295	1	TRIM CUSHION
3	621404	1	BARETT PIN
4	660057	1	LOOPS 30 MM
5	620114	1	BRACKET L=260
6	500214	4	PLASTIC RIVET



Parts Replacements List

620969
TRIM KIT SEAT CUSHION CT PLUSH BLACK 83
9000

Valid from 920504 to

Doc. R1-620969

Date 120511

Rev. 0

Rev.Date

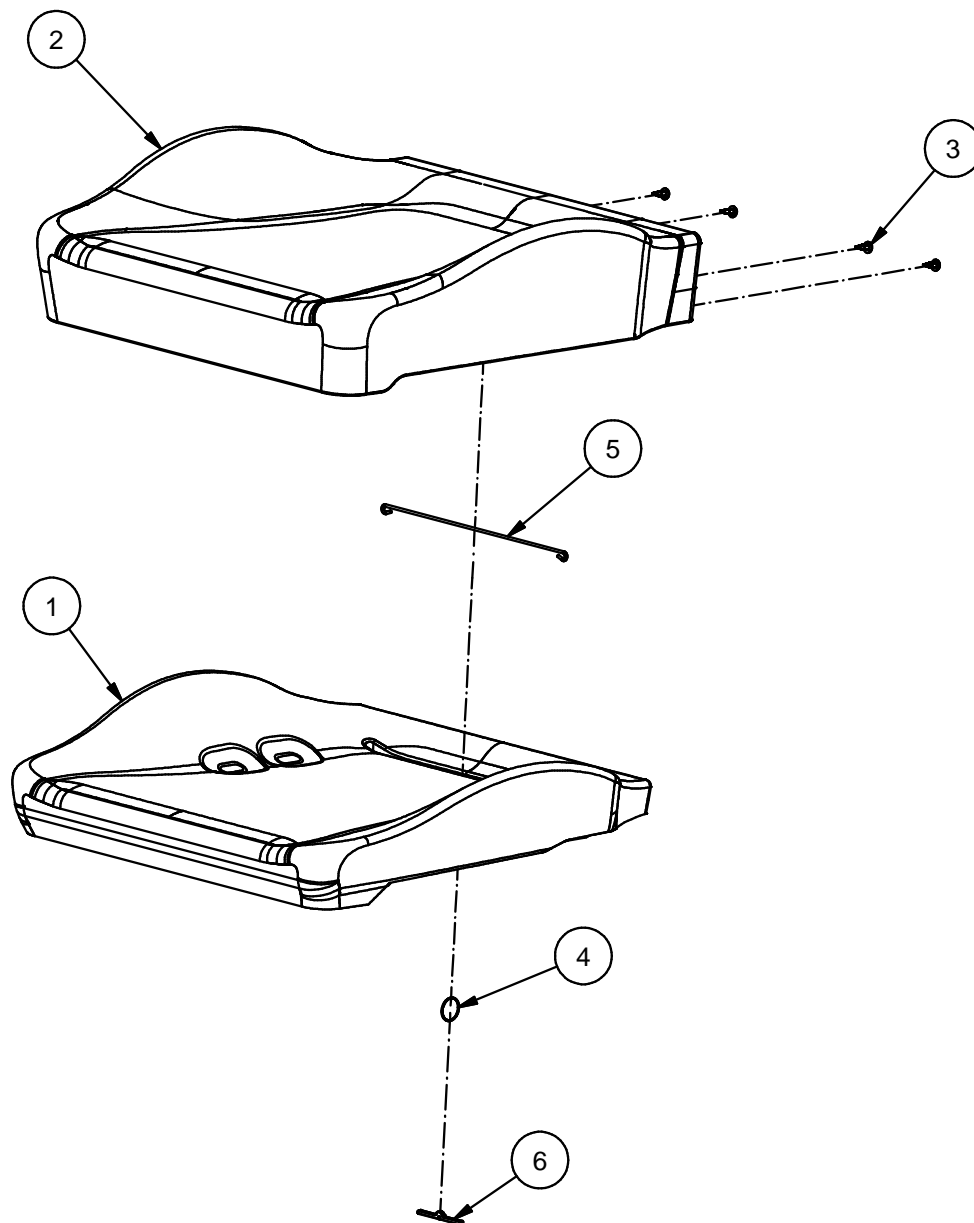

Fig.	Part. No.	Quantity	Description
1	500189	1	FOAM CUSHION
2	640295	1	TRIM CUSHION
3	500214	4	PLASTIC RIVET
4	660057	1	LOOPS 30 MM
5	620114	1	BRACKET L=260
6	621404	1	BARETT PIN



Parts Replacements List

628591
TRIM KIT BACKREST 640 NIGHTFALL
9000

Valid from 040501 to

Doc. R1-628591

Date 081124

Rev.

Rev.Date

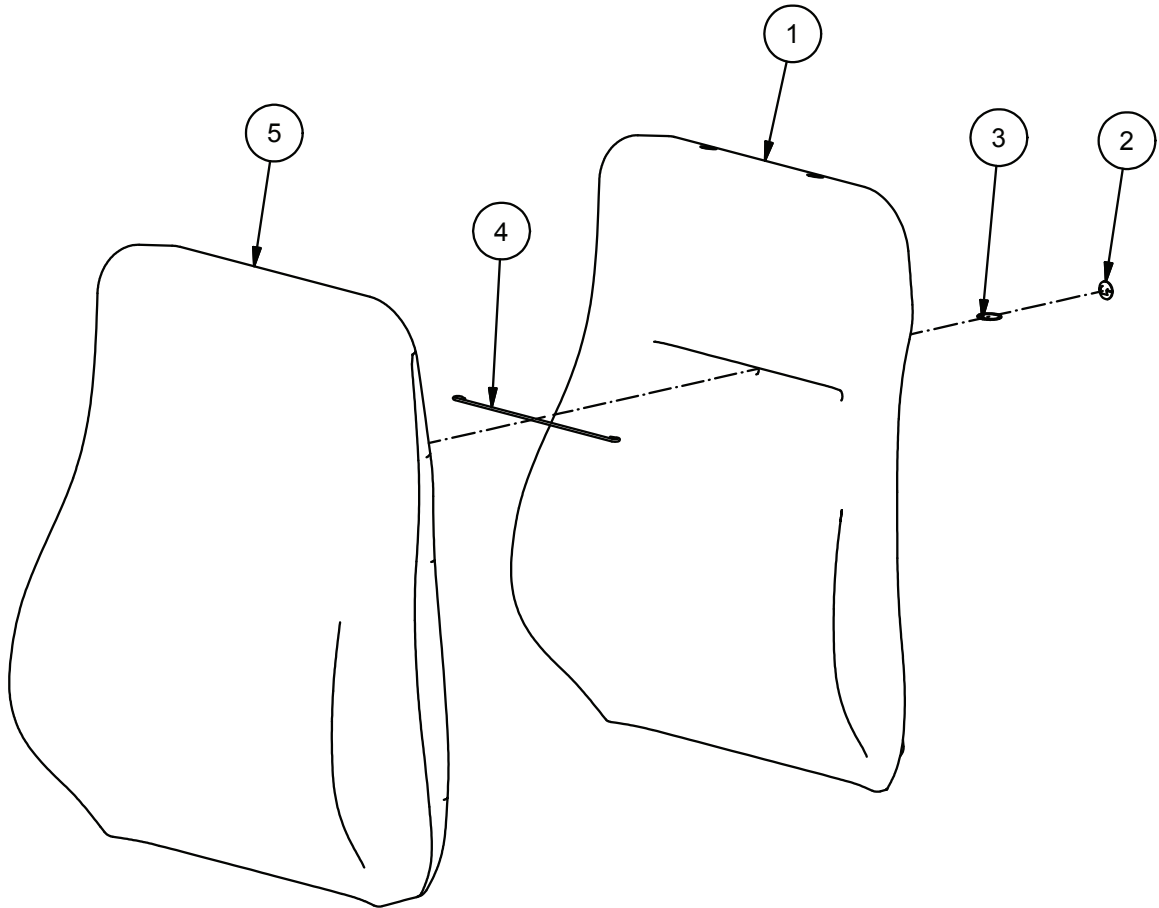

Fig.	Part. No.	Quantity	Description
1	620082	1	FOAM BACKREST 640
2	660054	1	BUTTOM SPK
3	660057	1	LOOPS 30 MM
4	620140	1	BRACKET L=230
5	641323	1	TRIM BACKREST 640
			NIGHTFALL



Parts Replacements List

628604

NIGHTFALL TRIM KIT BACKREST 640 3PB EPN 9000

Valid from 061206 to

Doc. R1-628604

Date 110124

Rev. 1

Rev.Date 110303

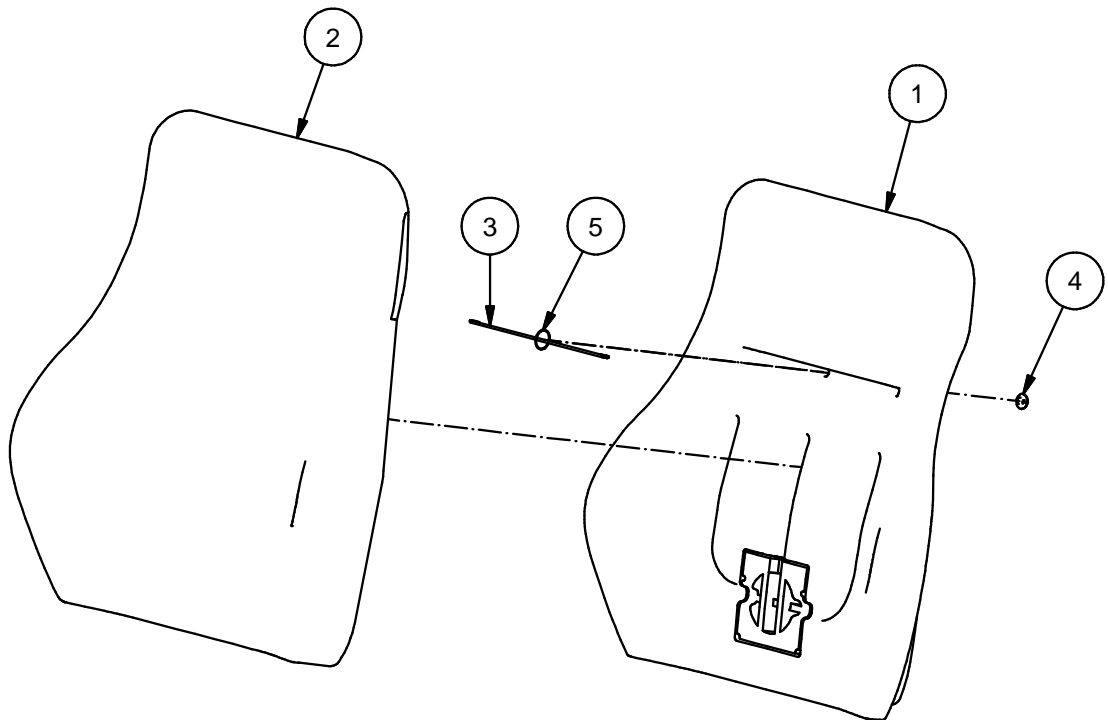

Fig.	Part. No.	Quantity	Description
1	621589	1	FOAM BACKREST 640 EPN
2	641326	1	TRIM BACKREST 640 EPN 9000
3	620140	1	BRACKET L=230
4	660054	1	BUTTOM SPK
5	660057	1	LOOPS 30 MM



Parts Replacements List

621025

**TRIM KIT BACKREST 640 ART. LEATHER GREY
9000**

Valid from 931210 to

Doc. R1-621025

Date 120508

Rev. 0

Rev.Date

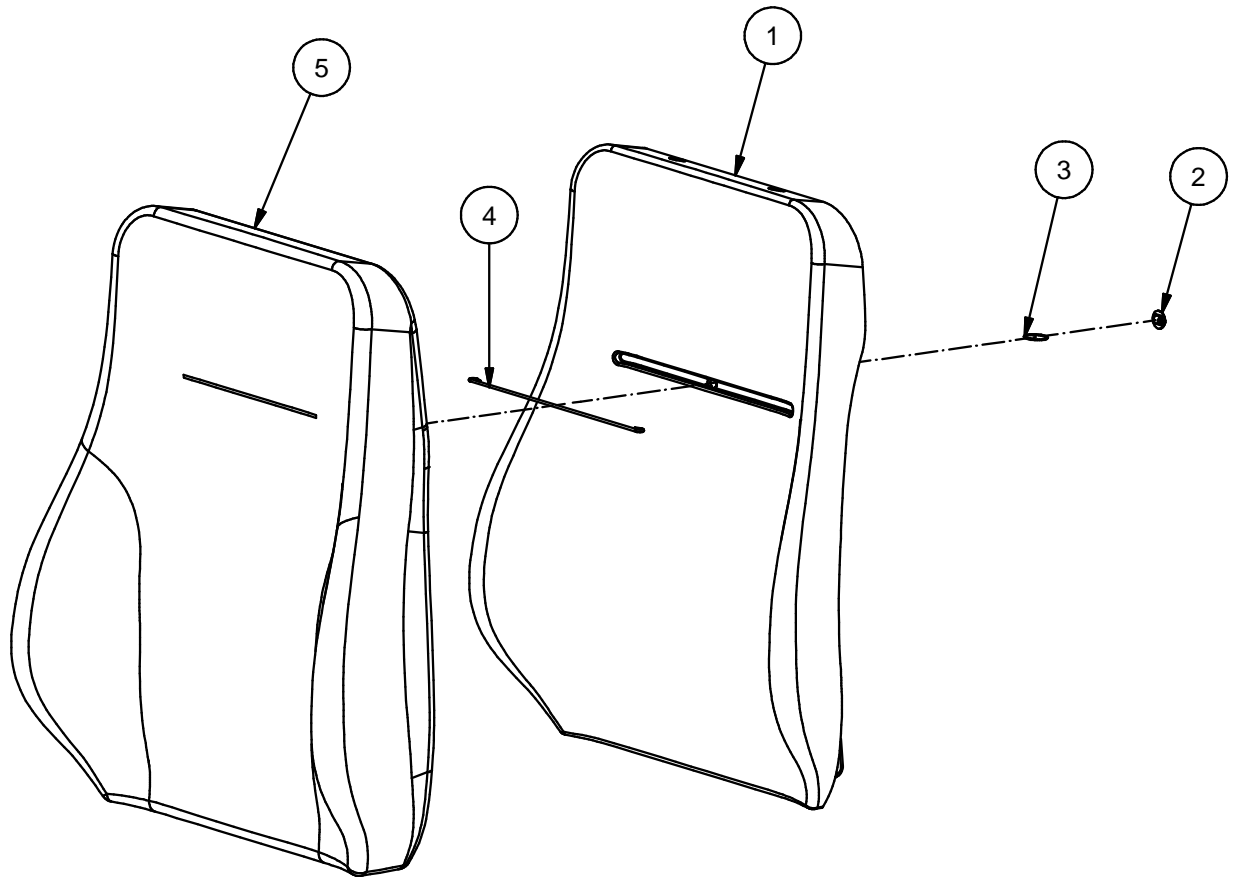

Fig.	Part. No.	Quantity	Description
1	620082	1	FOAM BACKREST 640
2	660054	1	BUTTOM SPK
3	660057	1	LOOPS 30 MM
4	620114	1	BRACKET L=260
5	500951	1	TRIM BACKREST 640
			ART. LEATHER GREY



Parts Replacements List

621026

**TRIM KIT BACKREST 640 LEATHER GREY
9000**

Valid from 931210 to

Doc. R1-621026

Date 120611

Rev. 0

Rev.Date

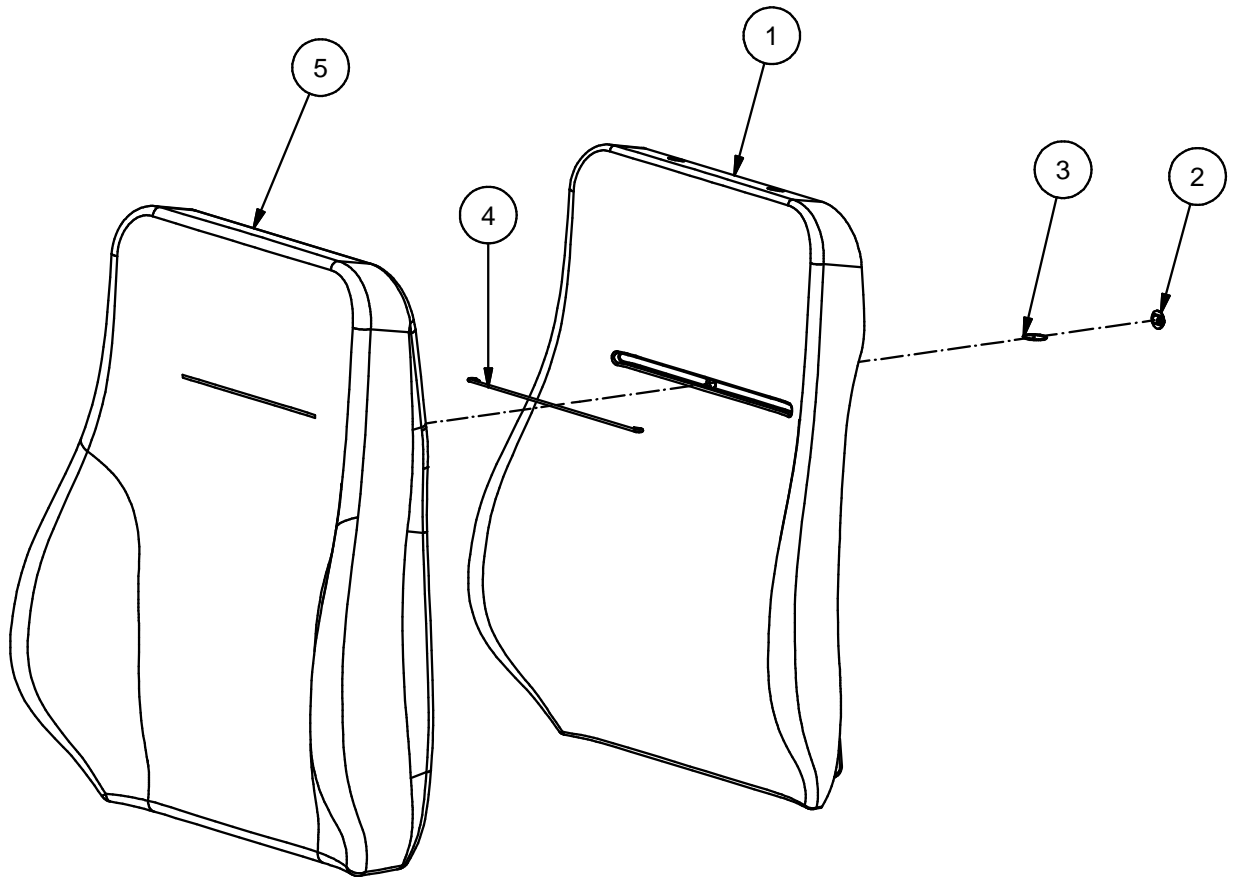

Fig.	Part. No.	Quantity	Description
1	620082	1	FOAM BACKREST 640
2	660054	1	BUTTOM SPK
3	660057	1	LOOPS 30 MM
4	620114	1	BRACKET L=260
5	500596	1	TRIM BACKREST 640
			LEATHER GREY BALTIQUE



Parts Replacements List

621031
TRIM KIT BACKREST 640 PLUSH BLUE 84
9000

Valid from 931210 to

Doc. R1-621031

Date 120508

Rev. 0

Rev.Date

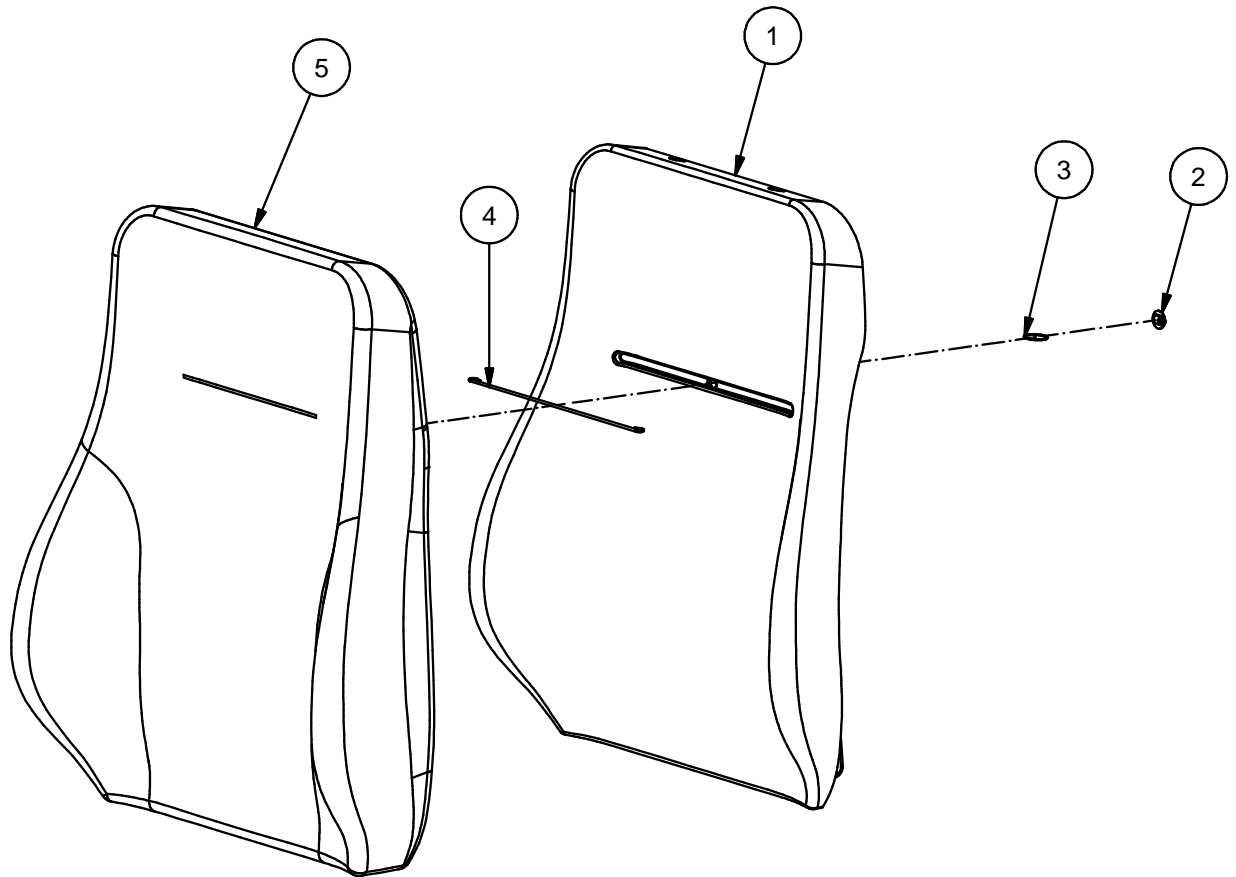

Fig.	Part. No.	Quantity	Description
1	620082	1	FOAM BACKREST 640
2	660054	1	BUTTOM SPK
3	660057	1	LOOPS 30 MM
4	620114	1	BRACKET L=260
5	640312	1	TRIM BACKREST 640
			PLUSH BLUE 84



Parts Replacements List

621032
TRIM KIT BACKREST 640 PLUSH RED 82
9000

Valid from 931210 to

Doc. R1-621032

Date 120611

Rev. 0

Rev.Date

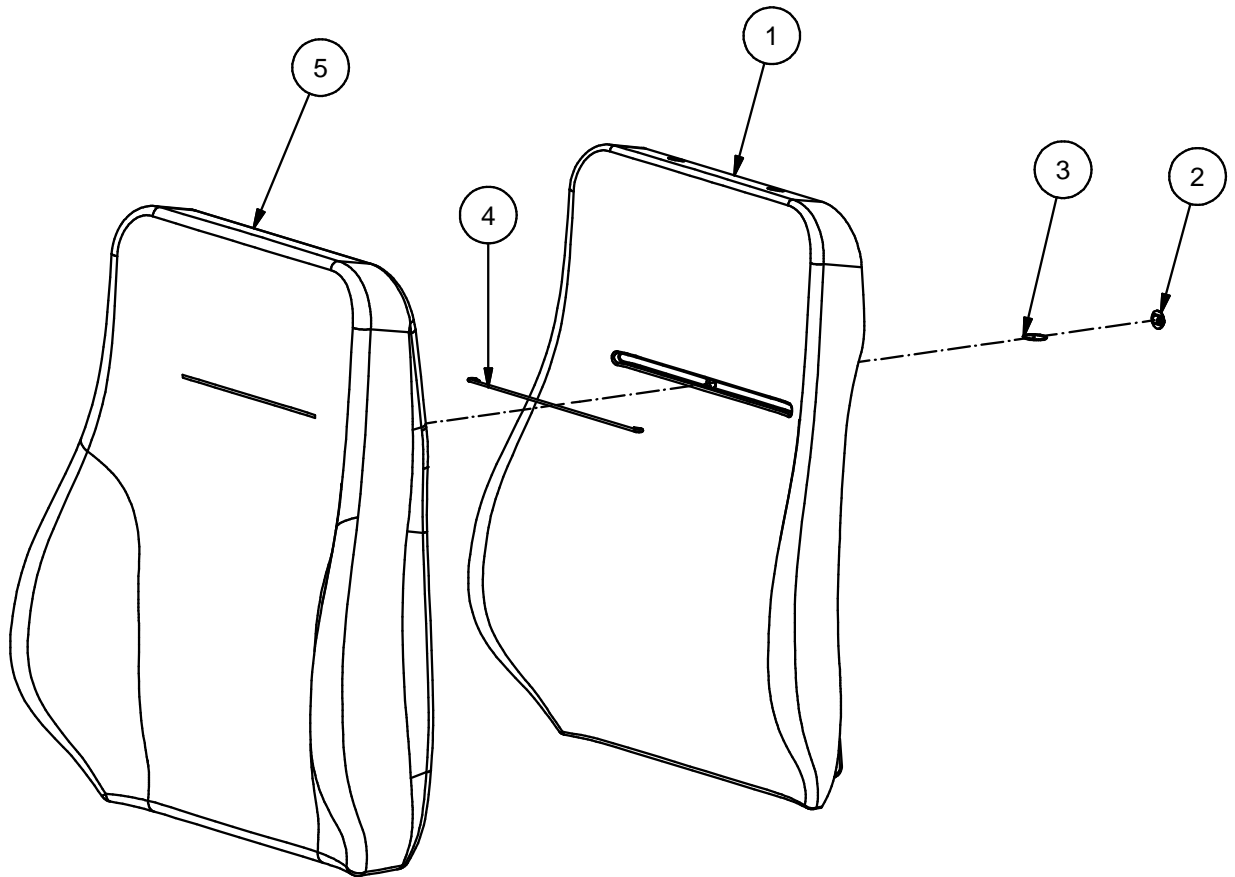

Fig.	Part. No.	Quantity	Description
1	620082	1	FOAM BACKREST 640
2	660054	1	BUTTOM SPK
3	660057	1	LOOPS 30 MM
4	620114	1	BRACKET L=260
5	640272	1	TRIM BACKREST 640
			PLUSH RED 82



Parts Replacements List

621033

**TRIM KIT BACKREST 640 PLUSH GREY 89
9000**

Valid from 931210 to

Doc. R1-621033

Date 120508

Rev. 0

Rev.Date

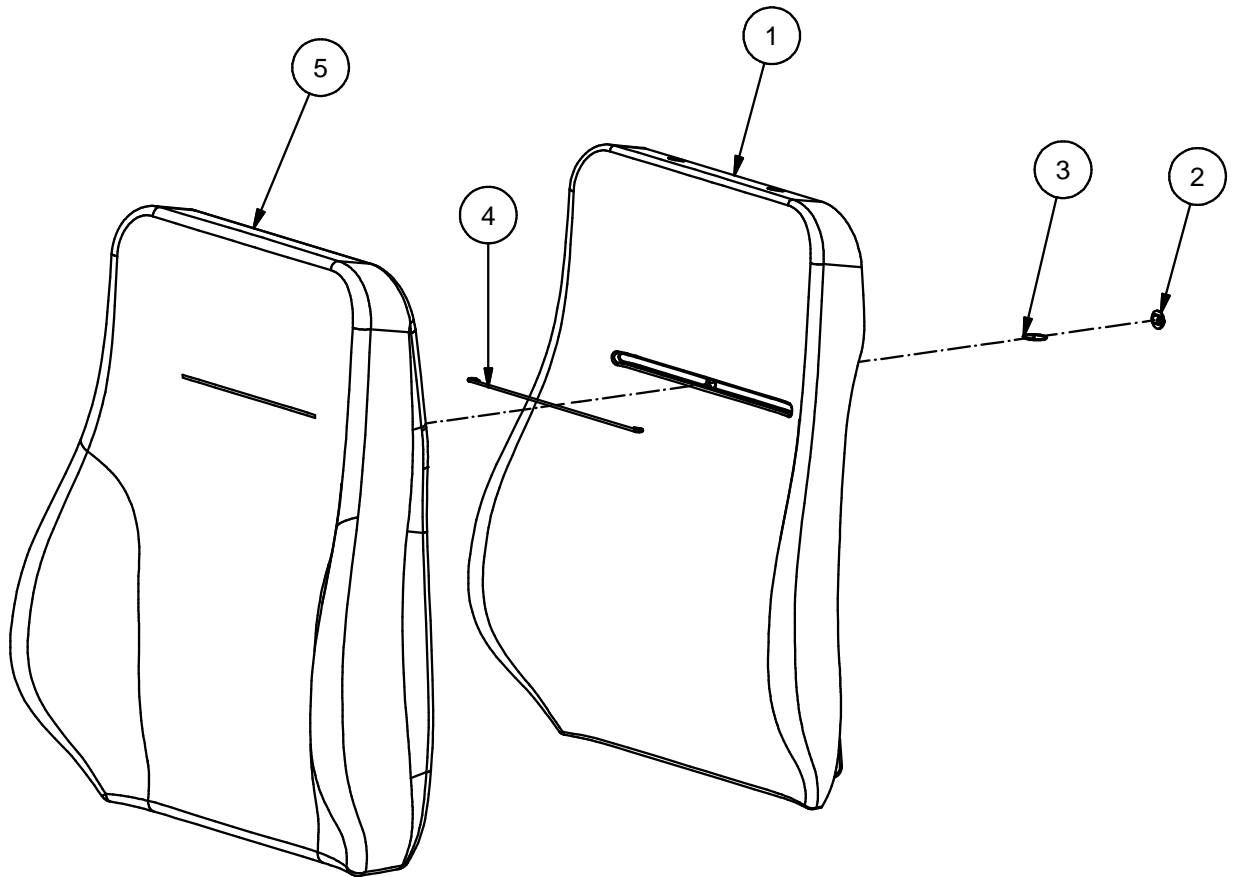

Fig.	Part. No.	Quantity	Description
1	620082	1	FOAM BACKREST 640
2	660054	1	BUTTOM SPK
3	660057	1	LOOPS 30 MM
4	620114	1	BRACKET L=260
5	640332	1	TRIM BACKREST 640
			PLUSH GREY 89



Parts Replacements List

621034

**TRIM KIT BACKREST 640 PLUSH BLACK 83
9000**

Valid from 931210 to

Doc. R1-621034

Date 120508

Rev. 0

Rev.Date

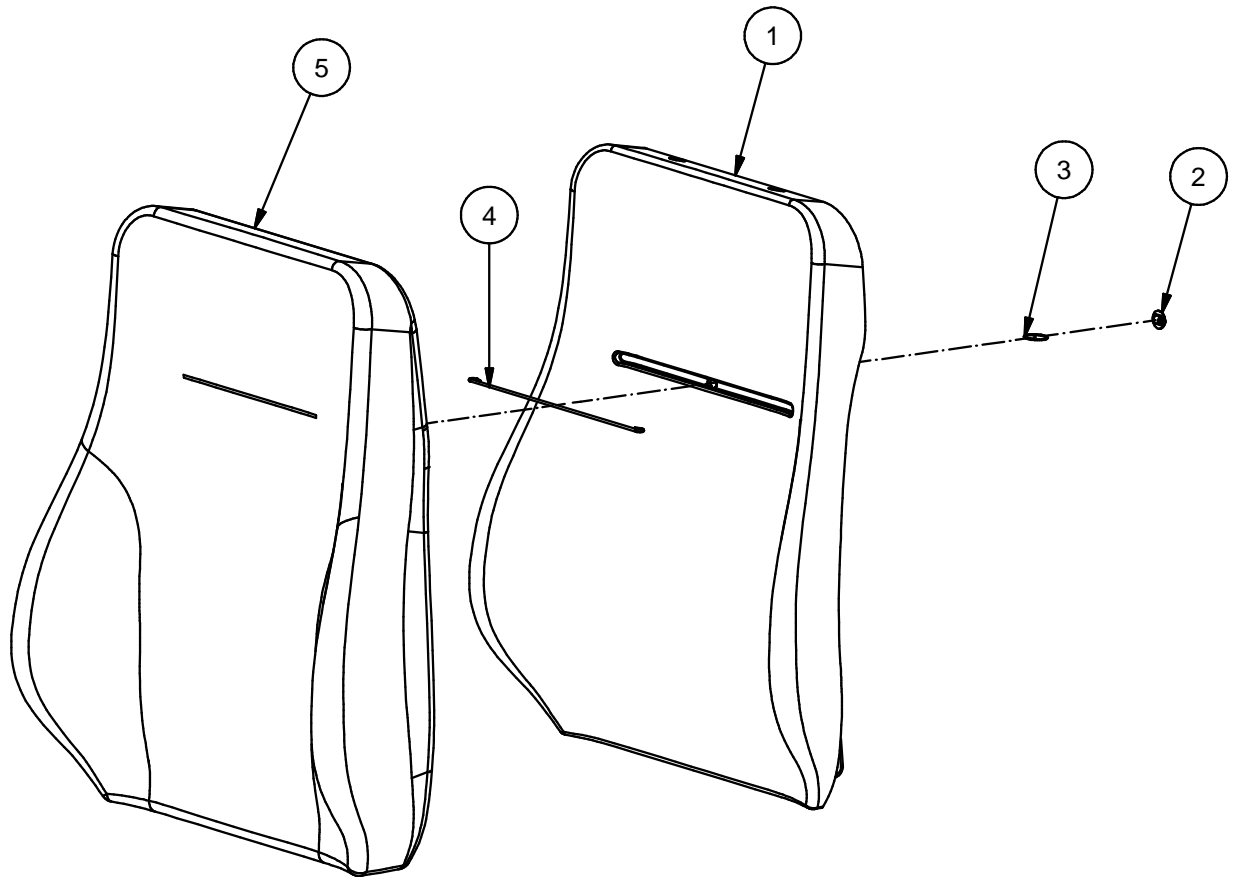

Fig.	Part. No.	Quantity	Description
1	620082	1	FOAM BACKREST 640
2	660054	1	BUTTOM SPK
3	660057	1	LOOPS 30 MM
4	620114	1	BRACKET L=260
5	640292	1	TRIM BACKREST 640
			PLUSH BLACK 83



Parts Replacements List

600602
HEAD REST NIGHTFALL
9000

Valid from 040501 to

Doc. R1-600602

Date 081124

Rev.

Rev.Date

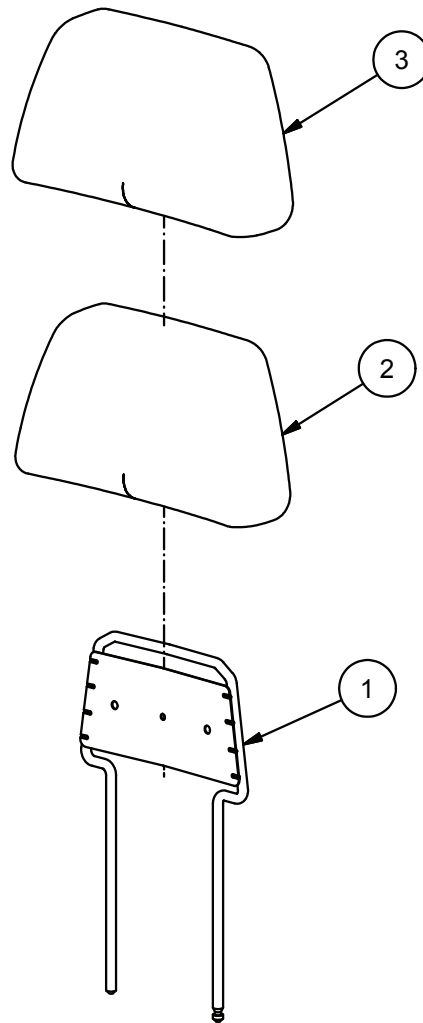

Fig.	Part. No.	Quantity	Description
1	500341	1	FRAME 9000
2	500344	1	FOAM HEAD REST
3	641322	1	TRIM HEADREST



Parts Replacements List

600505
HEADREST KIT ART. LEATEHR GREY
9000

Valid from 921126 to

Doc. R1-600505

Date 120508

Rev. 0

Rev.Date

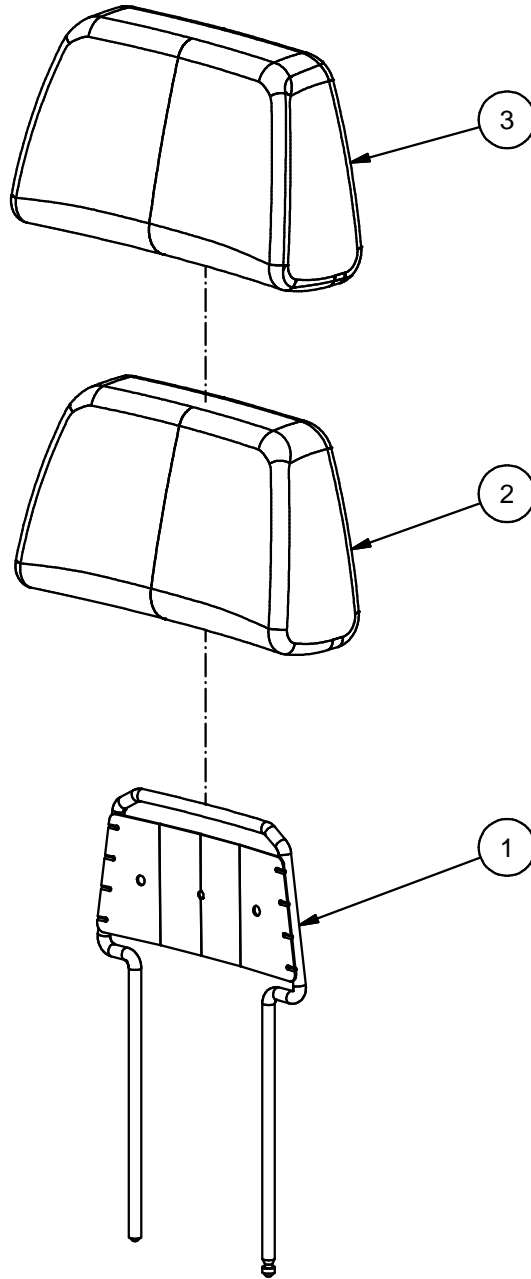

Fig.	Part. No.	Quantity	Description
1	500341	1	FRAME HEADREST
2	500344	1	FOAM HEAD REST
3	500950	1	TRIM HEADREST

ART. LEATHER GREY



Parts Replacements List

600506
HEADREST KIT LEATHER GREY
9000

Valid from 900807 to

Doc. R1-600506

Date 120611

Rev. 0

Rev.Date

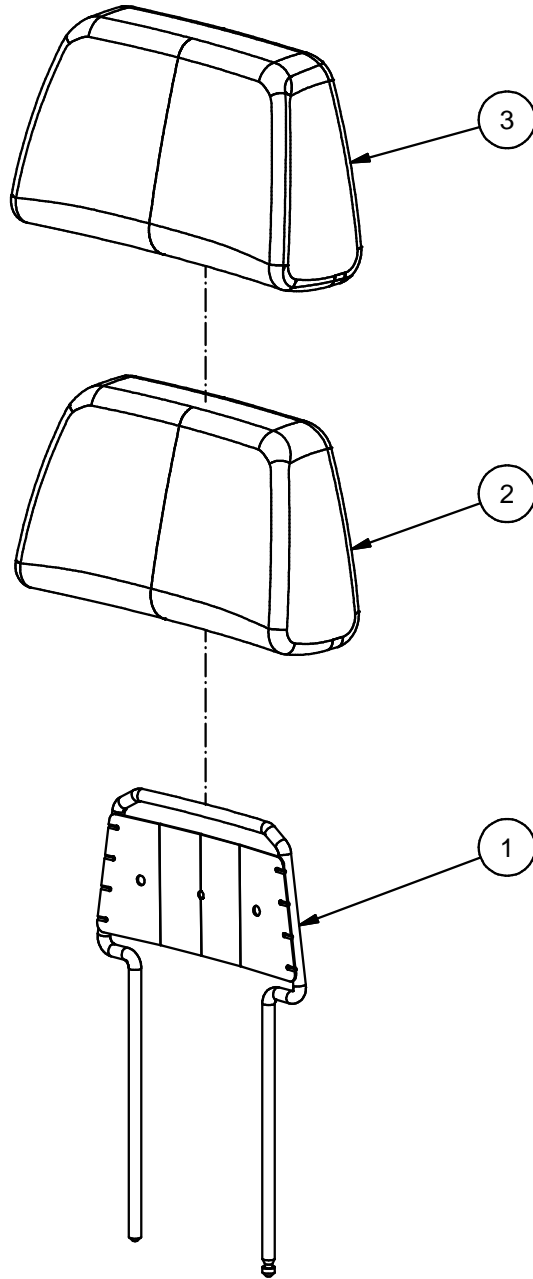

Fig.	Part. No.	Quantity	Description
1	500341	1	FRAME HEADREST
2	500344	1	FOAM HEAD REST
3	500626	1	TRIM HEADREST

LEATHER GREY BALTIQUE



Parts Replacements List

600520
HEADREST KIT PLUSH BLUE 84
9000

Valid from 921126 to

Doc. R1-600520

Date 120508

Rev. 0

Rev.Date

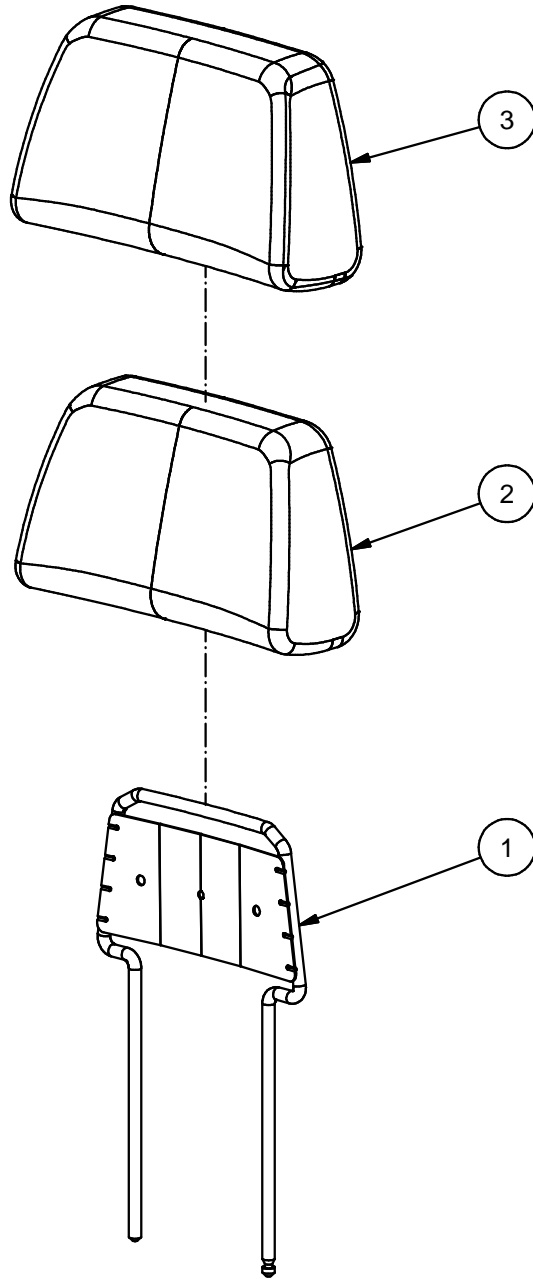

Fig.	Part. No.	Quantity	Description
1	500341	1	FRAME HEADREST
2	500344	1	FOAM HEAD REST
3	640311	1	TRIM HEADREST
			PLUSH BLUE 84



Parts Replacements List

600521
HEADREST KIT PLUSH RED 82
9000

Valid from 921126 to

Doc. R1-600521

Date 120611

Rev. 0

Rev.Date

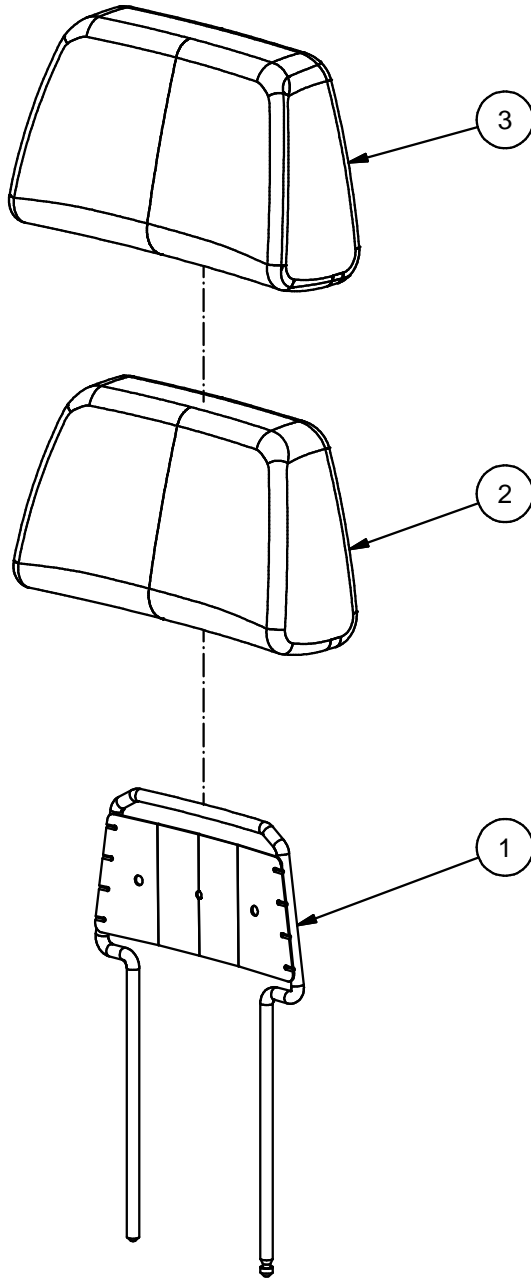

Fig.	Part. No.	Quantity	Description
1	500341	1	FRAME HEADREST
2	500344	1	FOAM HEAD REST
3	640271	1	TRIM HEADREST

PLUSH RED 82



Parts Replacements List

600523
HEADREST KIT PLUSH GREY 89
9000

Valid from 921126 to

Doc. R1-600523

Date 120508

Rev. 0

Rev.Date

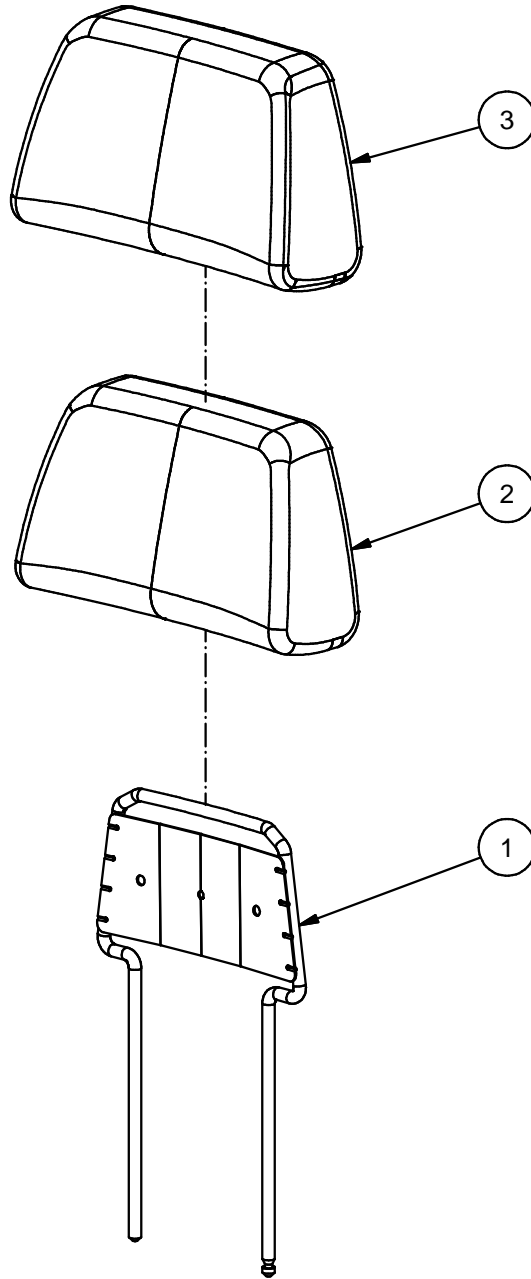

Fig.	Part. No.	Quantity	Description		
1	500341	1	FRAME HEADREST		
2	500344	1	FOAM HEAD REST		
3	640331	1	TRIM HEADREST		PLUSH GREY 89



Parts Replacements List

600524
HEADREST KIT PLUSH BLACK 83
9000

Valid from 921126 to

Doc. R1-600524

Date 120508

Rev. 0

Rev.Date

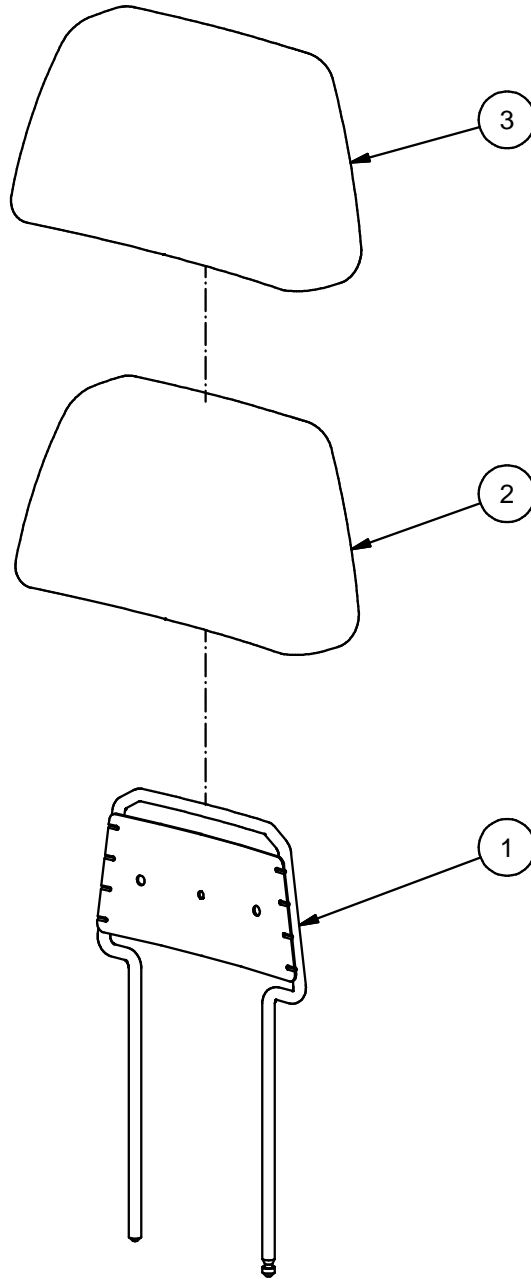

Fig.	Part. No.	Quantity	Description
1	500341	1	FRAME HEADREST
2	500344	1	FOAM HEAD REST
3	640291	1	TRIM HEADREST
			PLUSH BLACK 83



Parts Replacements List

600603
HEADREST KIT NIGHTFALL 4-WAY
9000

Valid from 040506 to

Doc. R1-600603

Date 120508

Rev. 0

Rev.Date

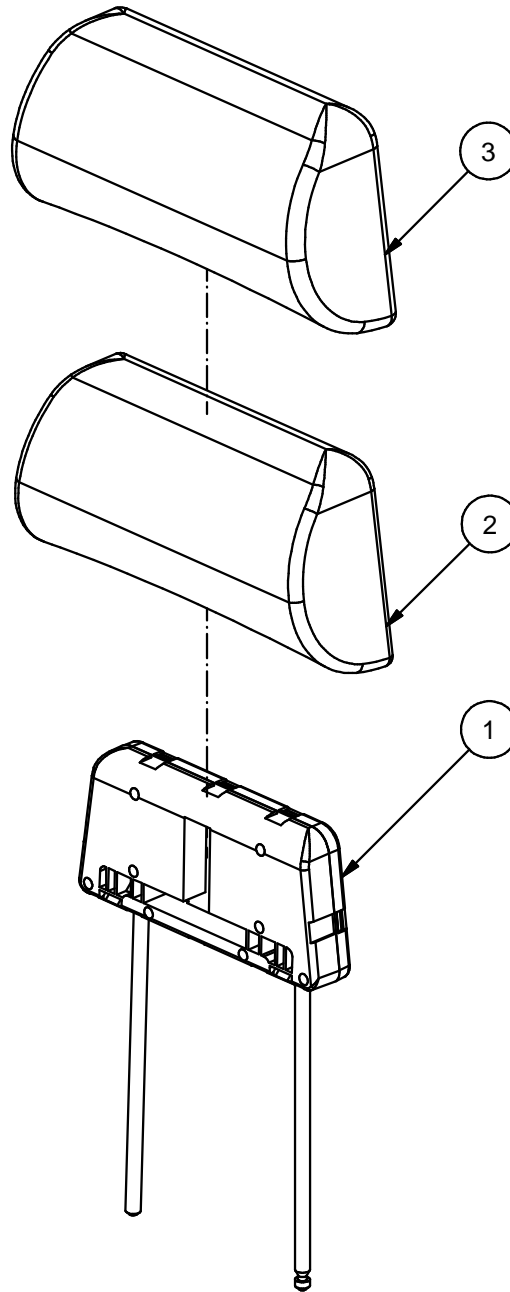

Fig.	Part. No.	Quantity	Description
2	621513	1	HEAD REST FOAM 4-WAYS
1	621567	1	HEAD REST FRAMEWORK ASM
3	641023	1	TRIM HEAD REST 4-WAYS, NIGHTFALL



Parts Replacements List

600532
HEADREST KIT LEATHER BLACK
9000

Valid from 010910 to

Doc. R1-600532

Date 120611

Rev. 0

Rev.Date

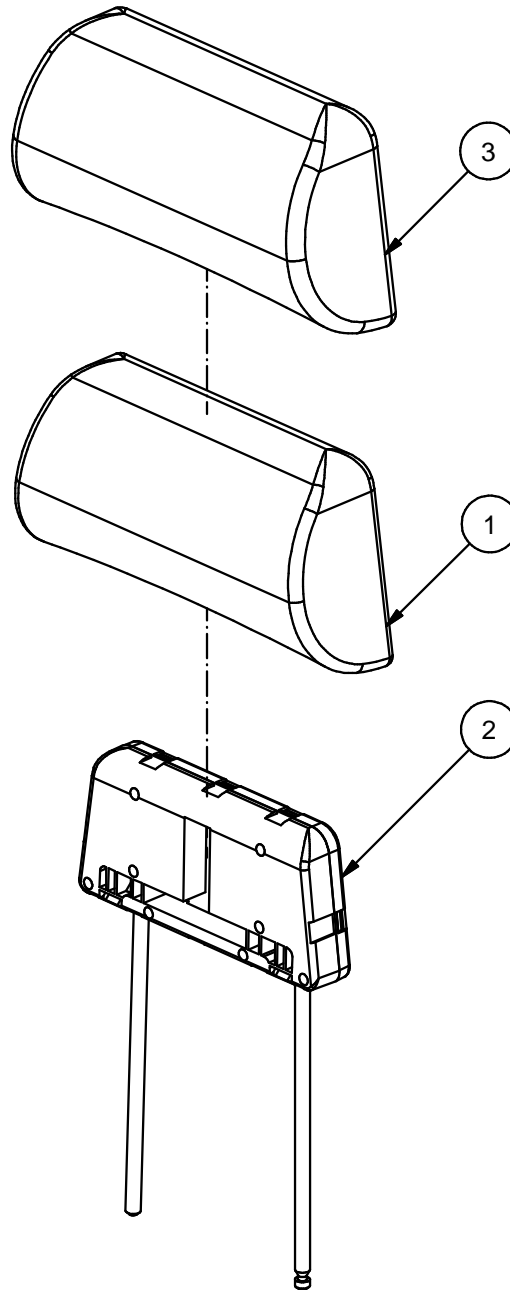

Fig.	Part. No.	Quantity	Description		
1	621513	1	HEAD REST FOAM 4-WAYS		
2	621567	1	HEAD REST FRAMEWORK ASM		
3	640478	1	TRIM HEAD REST 4-WAYS		LEATHER BLACK



Parts Replacements List

600530

**HEADREST KIT PLUSH BLACK 83 4-WAY
9000**

Valid from 010910 to

Doc. R1-600530

Date 120601

Rev. 0

Rev.Date

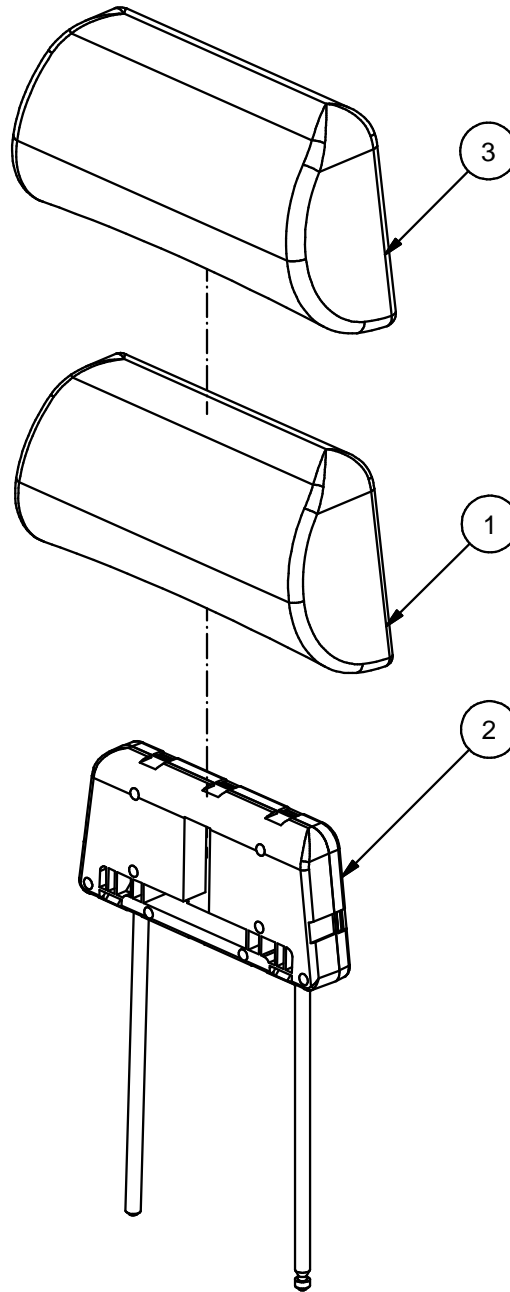

Fig.	Part. No.	Quantity	Description		
1	621513	1	HEAD REST FOAM 4-WAYS		
2	621567	1	HEAD REST FRAMEWORK ASM		
3	640290	1	TRIM HEAD REST 4-WAYS		PLUSH BLACK 83



Parts Replacements List

501091
HEATING ELEMENT 24V
9000

Valid from 880502 to

Doc. R1-501091

Date 100914

Rev. 0

Rev.Date

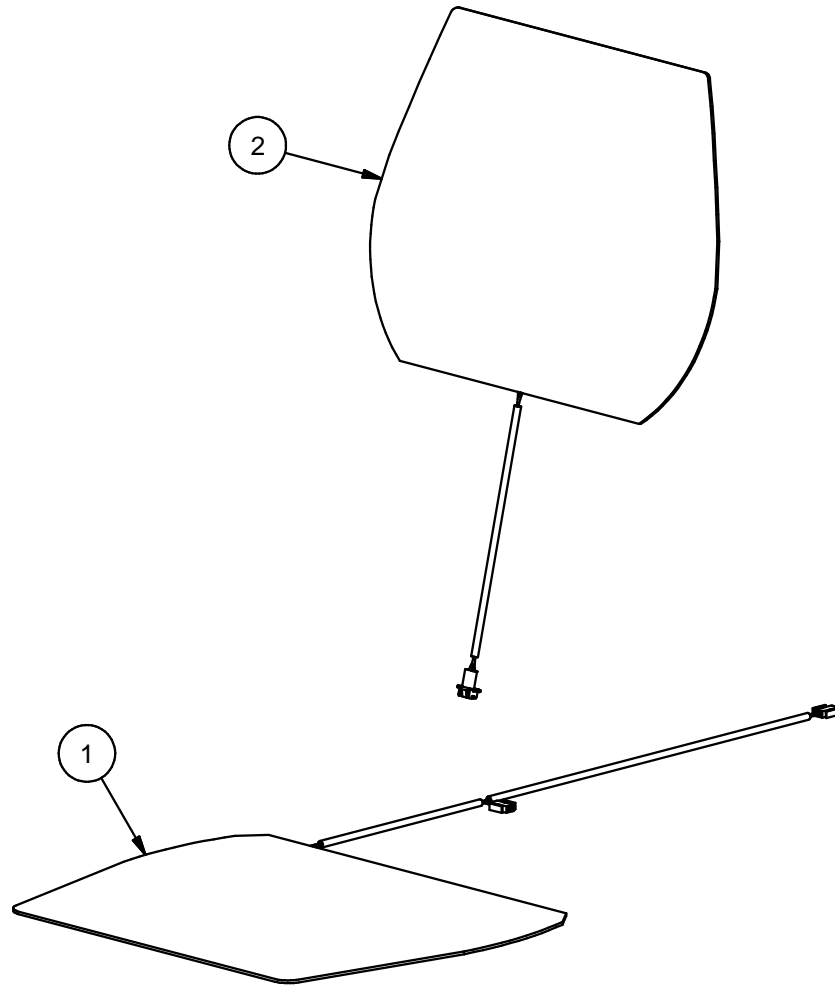

Fig.	Part. No.	Quantity	Description	
1	500357	1	HEATING ELEMENT 24V	CUSHION
2	500358	1	HEATING ELEMENT 24V	SQUAB



Parts Replacements List

603038
HEATING ELEMENT 24V LEATHER
9000

Valid from 920811 to

Doc. R1-603038

Date 120614

Rev. 0

Rev.Date

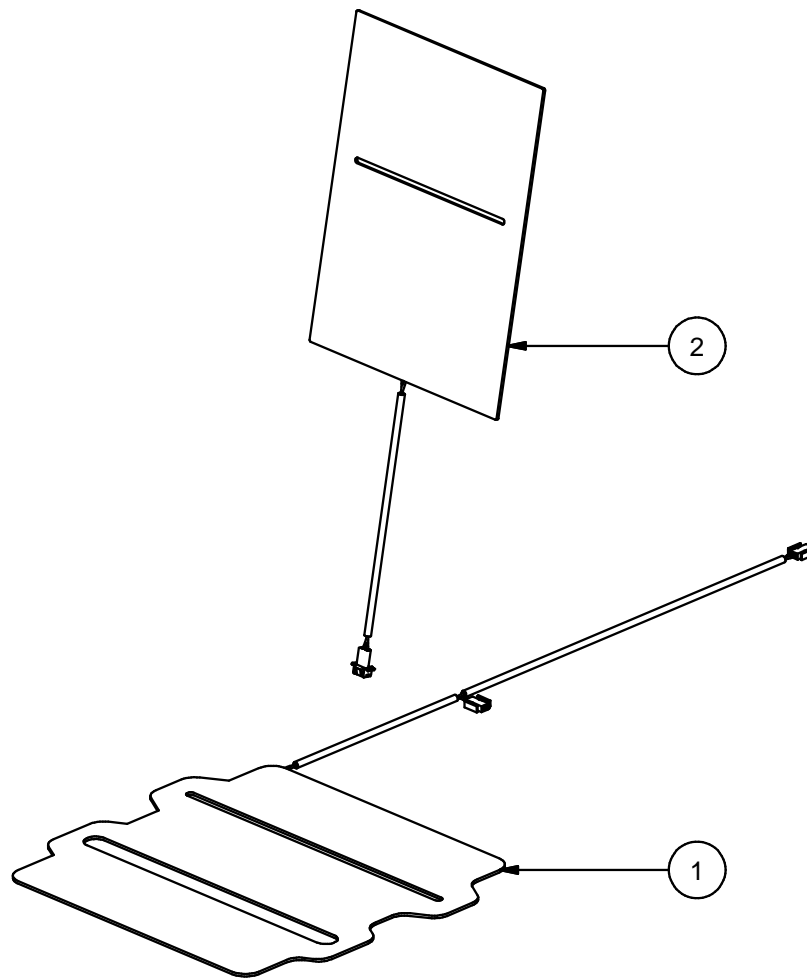

Fig.	Part. No.	Quantity	Description
1	500567	1	HEATING ELEMENT 24V CUSHION
2	500568	1	HEATING ELEMENT 24V SQUAB



Parts Replacements List

603124
MICRO SWITCH IP40
9000

Valid from 070611 to

Doc. R1-603124

Date 120507

Rev. 0

Rev.Date

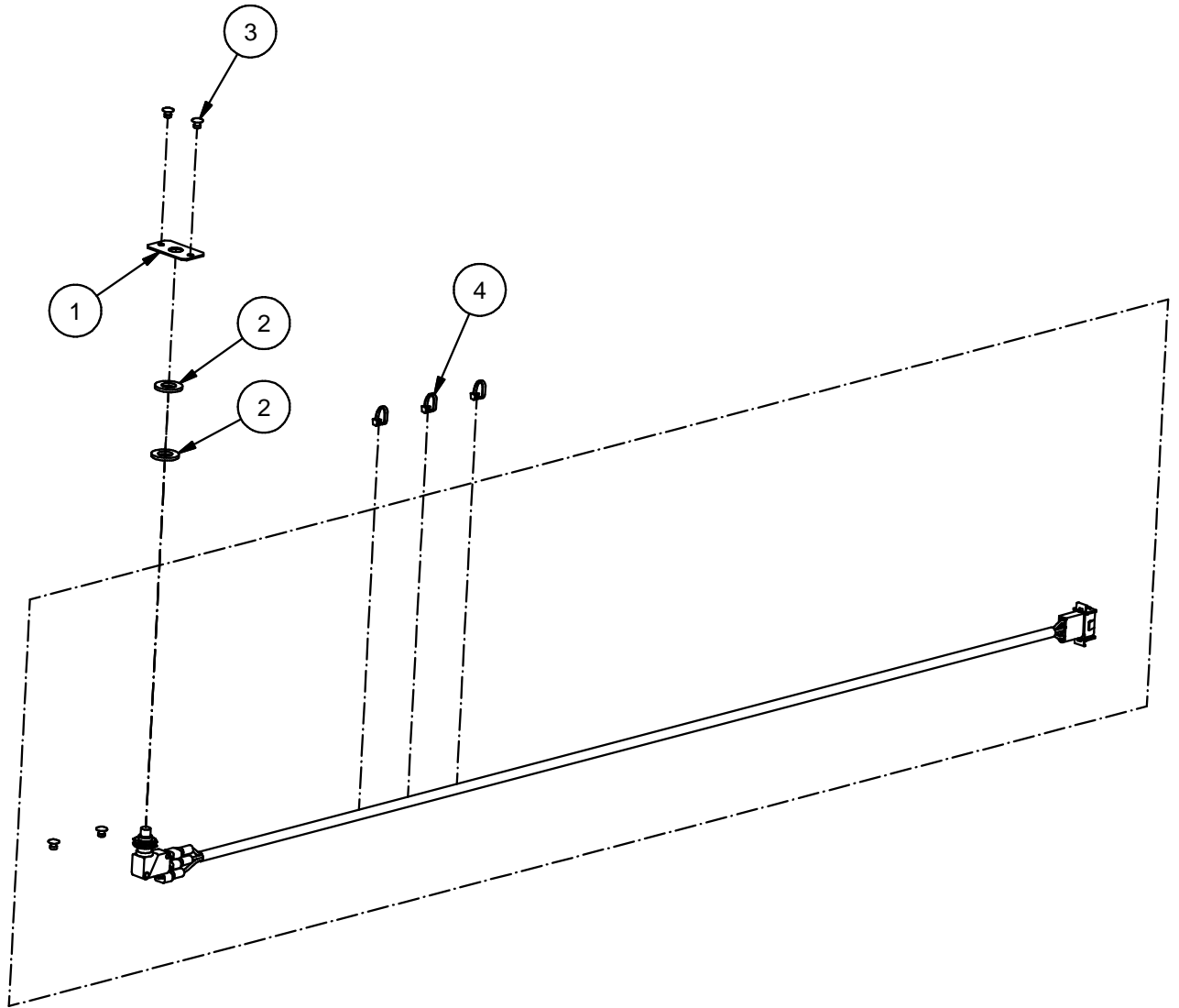

Fig.	Part. No.	Quantity	Description		
1	628684	1	BRACKET MICROSWITCH		
2	561027	2	WASHER	10.5x20x2	
3	653000	4	RIVET AL/ST	4.0x7	AP/D BS
4	500317	3	CABLE TIE	200x4.6	WHITE
5	629342	1	MICROSWITCH IP40		



Parts Replacements List

603126

**MICRO SWITCH IP40+BUZZER 24V
9000**

Valid from 070611 to

Doc. R1-603126

Date 110428

Rev. 0

Rev.Date

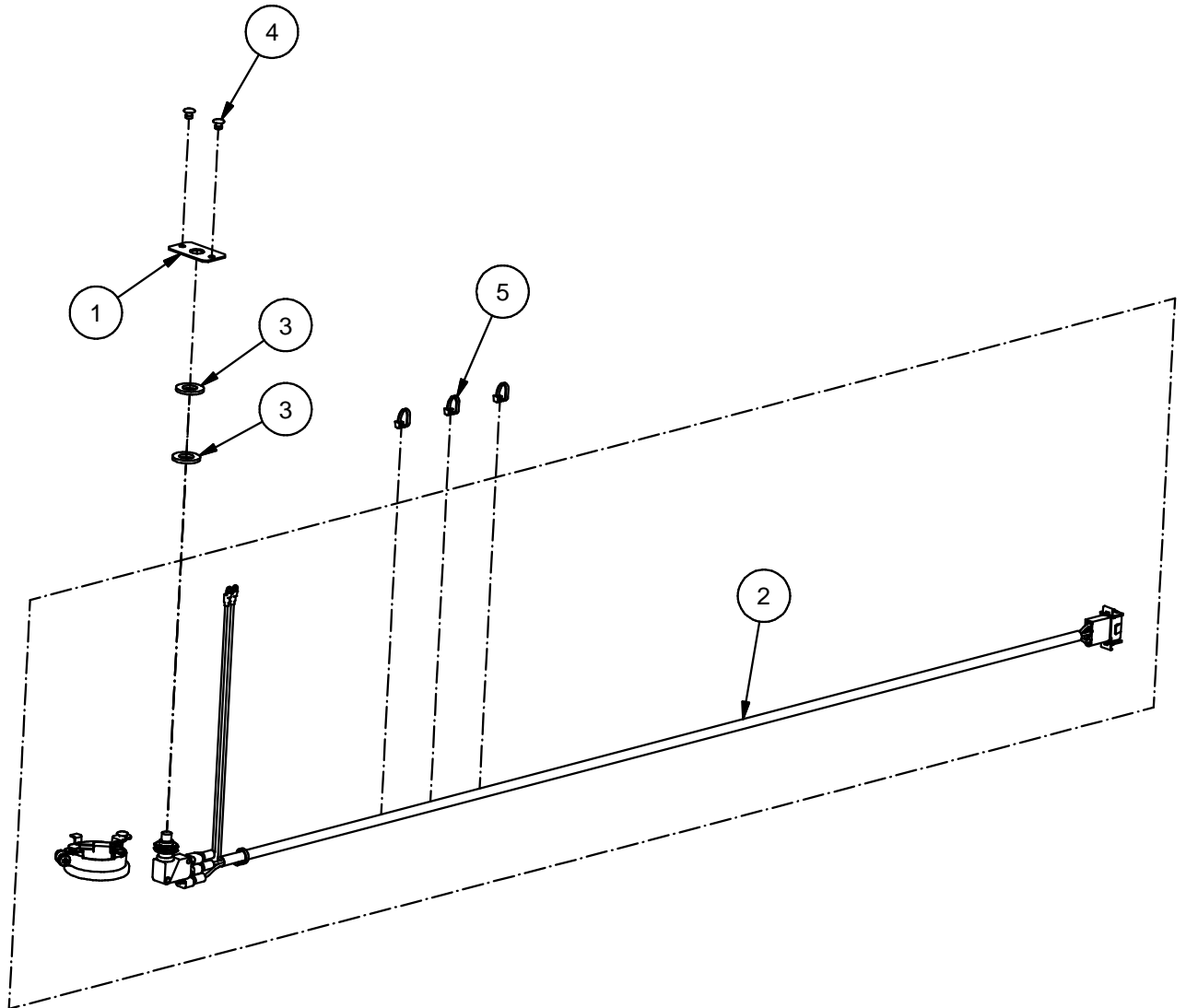

Fig.	Part. No.	Quantity	Description		
1	628684	1	BRACKET MICROSWITCH		
2	629349	1	MICRO SWITCH IP40		
3	561027	2	WASHER	10.5x20x2	
4	653000	4	RIVET AL/ST	4.0x7	AP/D BS
5	500317	3	CABLE TIE	200x4.6	WHITE



Parts Replacements List

603127
MICRO SWITCH IP57
9000

Valid from 070611 to

Doc. R1-603127

Date 120504

Rev. 0

Rev.Date

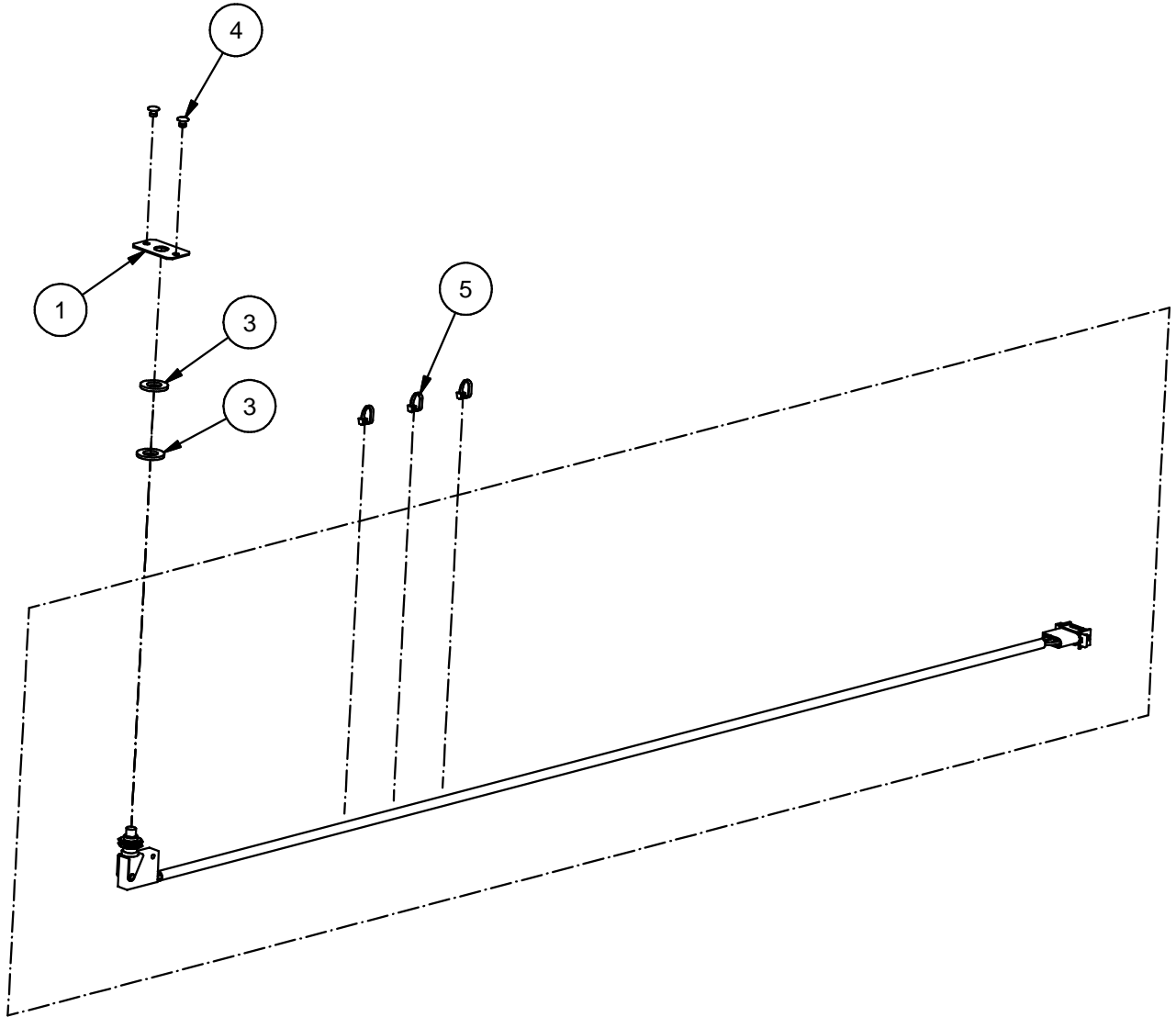

Fig.	Part. No.	Quantity	Description		
1	628684	1	BRACKET MICROSWITCH		
3	561027	2	WASHER	10.5x20x2	
4	653000	2	RIVET AL/ST	4.0x7	AP/D BS
5	500317	3	CABLE TIE	200x4.6	WHITE
7	629346	1	MICROSWITCH IP57		



Parts Replacements List

603129

**MICRO SWITCH IP57+BUZZER 24V
9000**

Valid from 070611 to

Doc. R1-603129

Date 120504

Rev. 0

Rev.Date

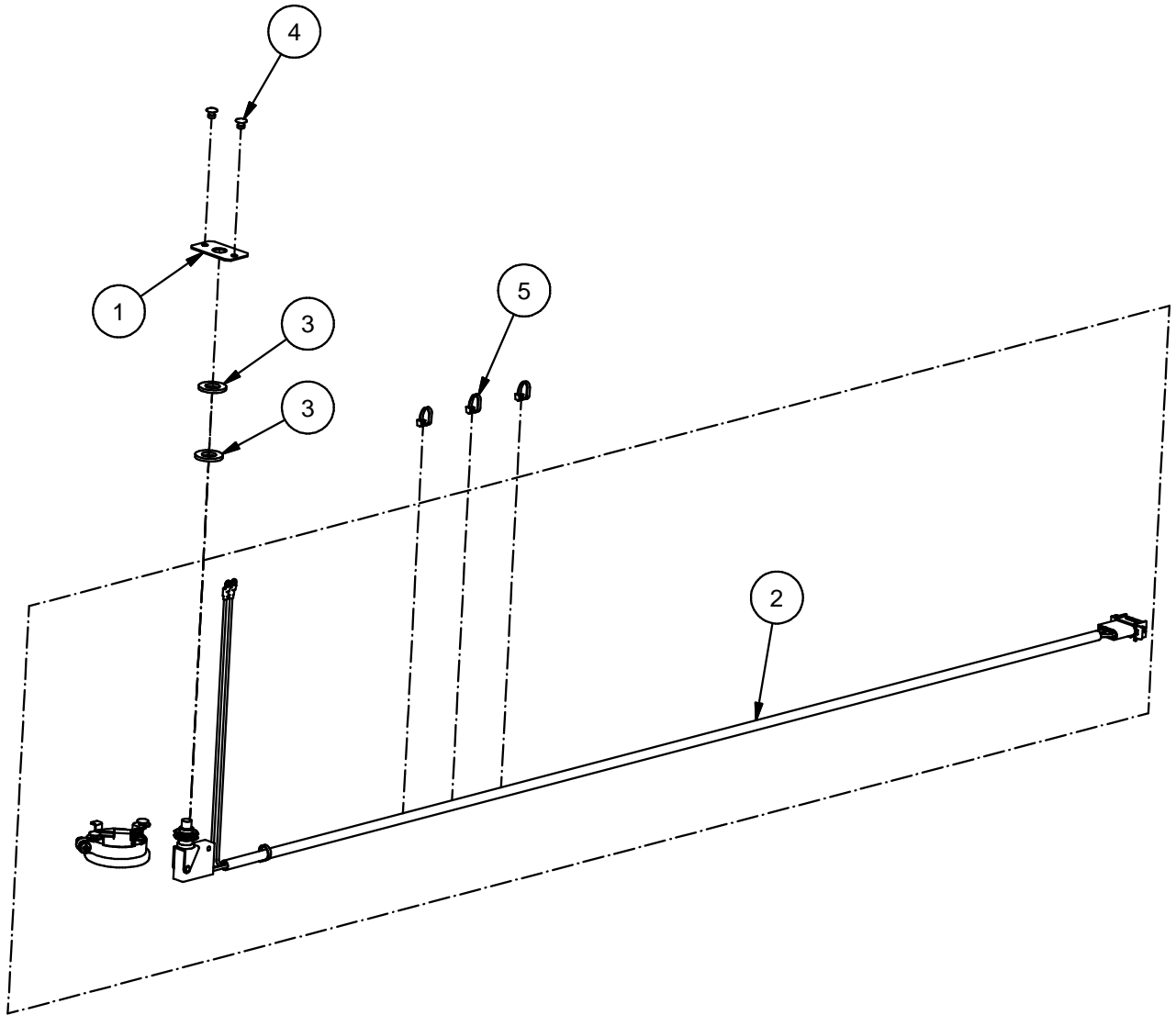

Fig.	Part. No.	Quantity	Description		
1	628684	1	BRACKET MICROSWITCH		
2	629351	1	MICRO SWITCH IP57		
3	561027	2	WASHER	10.5x20x2	
4	653000	4	RIVET AL/ST	4.0x7	AP/D BS
5	500317	3	CABLE TIE	200x4.6	WHITE



Parts Replacements List

603004
SHOCK ABSORBER AIR
9000

Valid from 920224 to

Doc. R1-603004

Date 120607

Rev. 0

Rev.Date

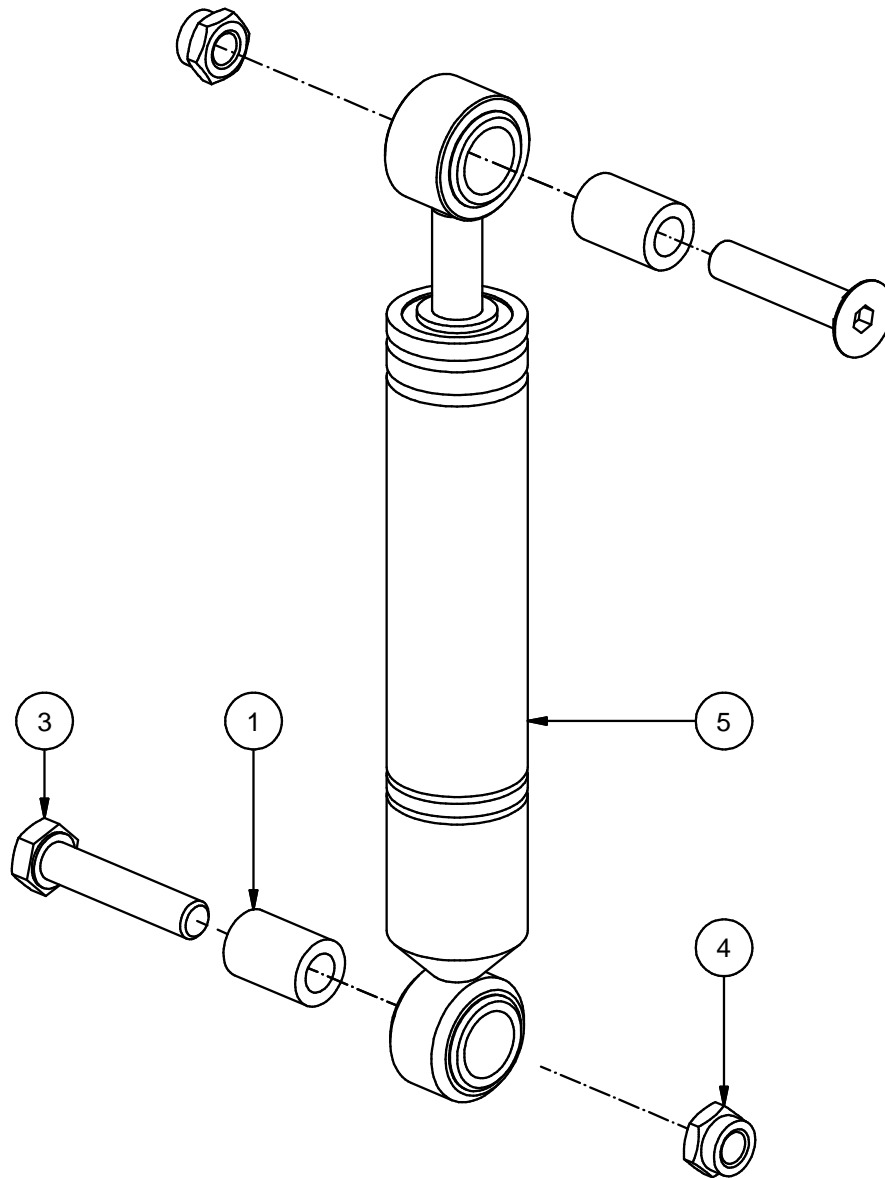

Fig.	Part. No.	Quantity	Description		
1	620085	2	BUSHING		
2	650054	1	SCREW MF6S	M8x40	DIN7991 ZN 8.8
3	650015	1	SCREW M6S	M8x40	DIN931 ZN 8.8
4	210401	2	LOCKING NUT	M8	DIN6925 ZN K8
5	500122	1	SHOCK ABSORBER		



Parts Replacements List

603114
SIDE SUPPORT BACKREST
9000

Valid from 051027 to

Doc. R1-603114

Date 100518

Rev.

Rev.Date

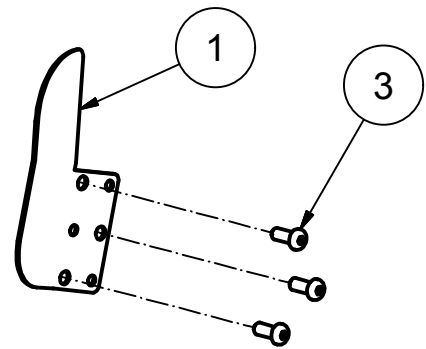
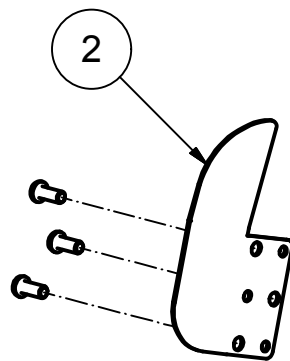

Fig.	Part. No.	Quantity	Description		
1	628868	1	SIDE SUPPORT LEFT		
2	628869	1	SIDE SUPPORT RIGHT		
3	650059	6	SCREW K6S	M8x20	ZN 10.9
4	673294	1	CLEANING NAPKIN 3M VHB		(NOT IN EXPLODED VIEW)
5	673293	0.16 LPM	TAPE 3M 5925	W=19 MM	(NOT IN EXPLODED VIEW)



Parts Replacements List

603115
SIDE SUPPORT BACKREST QR
9000

Valid from 970813 to

Doc. R1-603115

Date 120504

Rev. 0

Rev.Date

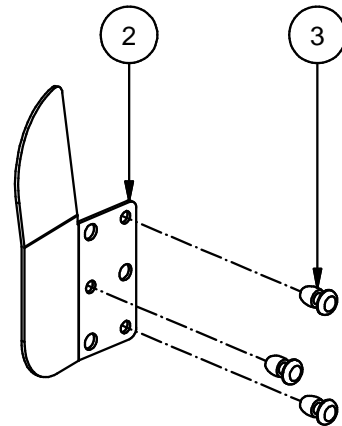
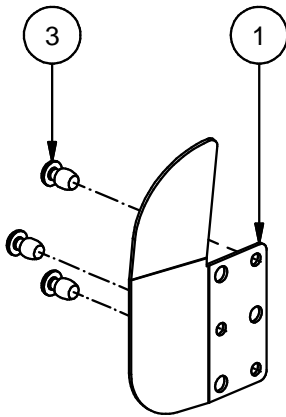

Fig.	Part. No.	Quantity	Description		
1	628869	1	SIDE SUPPORT RIGHT		
2	628868	1	SIDE SUPPORT LEFT		
3	500220	6	RIVET ST/ST	6,4x15	SP/D BS
4	673294	1	CLEANING NAPKIN 3M VHB		(NOT IN EXPLODED VIEW)
5	673293	1	TAPE 3M 5925	W=19 MM	(NOT IN EXPLODED VIEW)